

IMPLANTOLOGY

 Outlink²

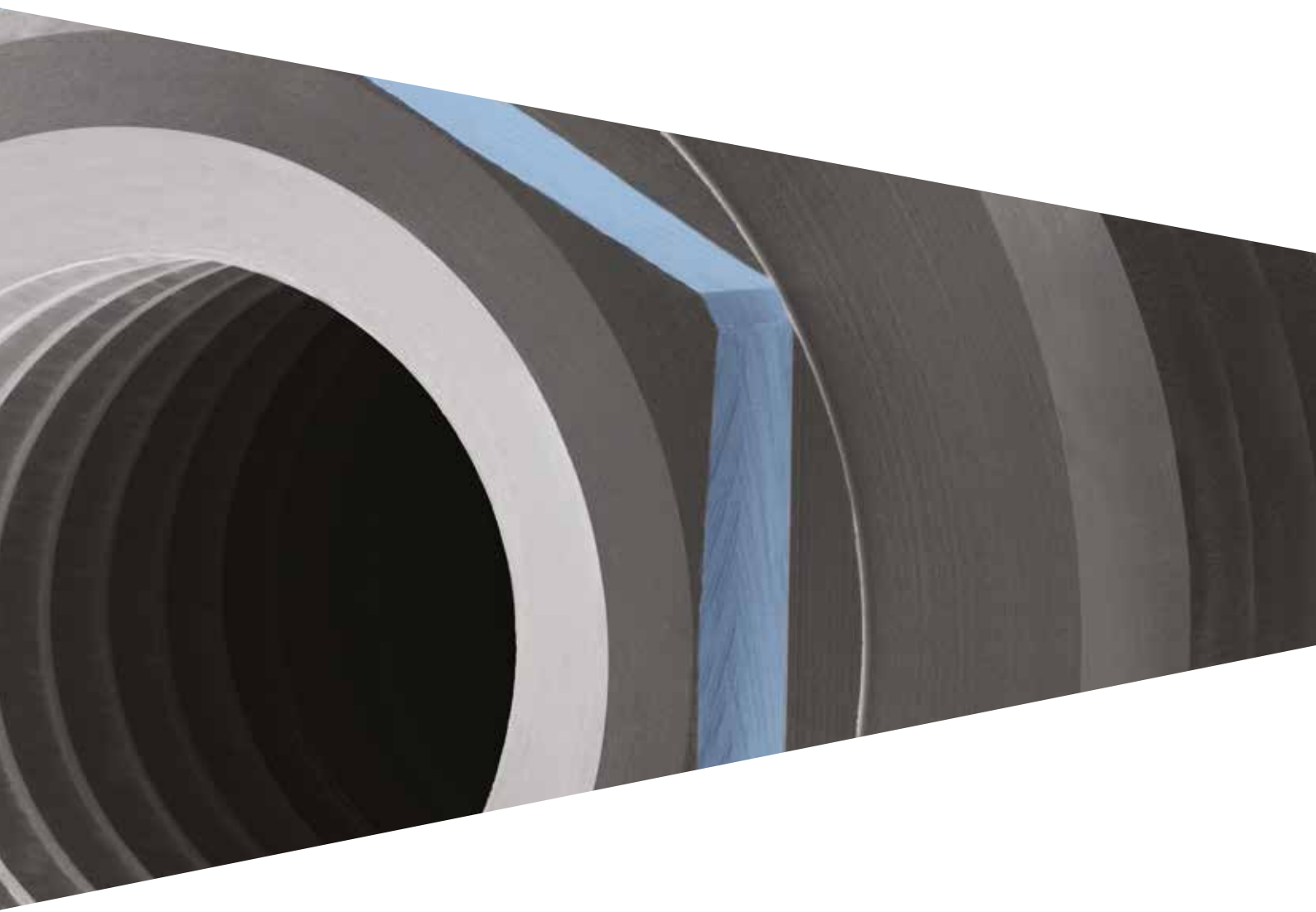

sweden & martina

IMPLANTOLOGY TABLE OF CONTENTS



Implant system

06



The range

18



Surgical instruments

20



Guide to the choice
of prosthetic solutions

44



Prosthetic components

46



Material composition

86



Bibliography on
Sweden & Martina implants

90

Sweden & Martina develops and manufactures implant systems that offer both excellent clinical functionality and perfect aesthetic results. The surfaces have been designed to obtain the best relationships between the surface roughness of the titanium and speed of bone healing. The surgical instruments are functional, easy to use and ergonomic. Training courses, continuous refresher courses and extensive assistance distinguish the service and reliability that have made Sweden & Martina a leader in the Italian implant market.

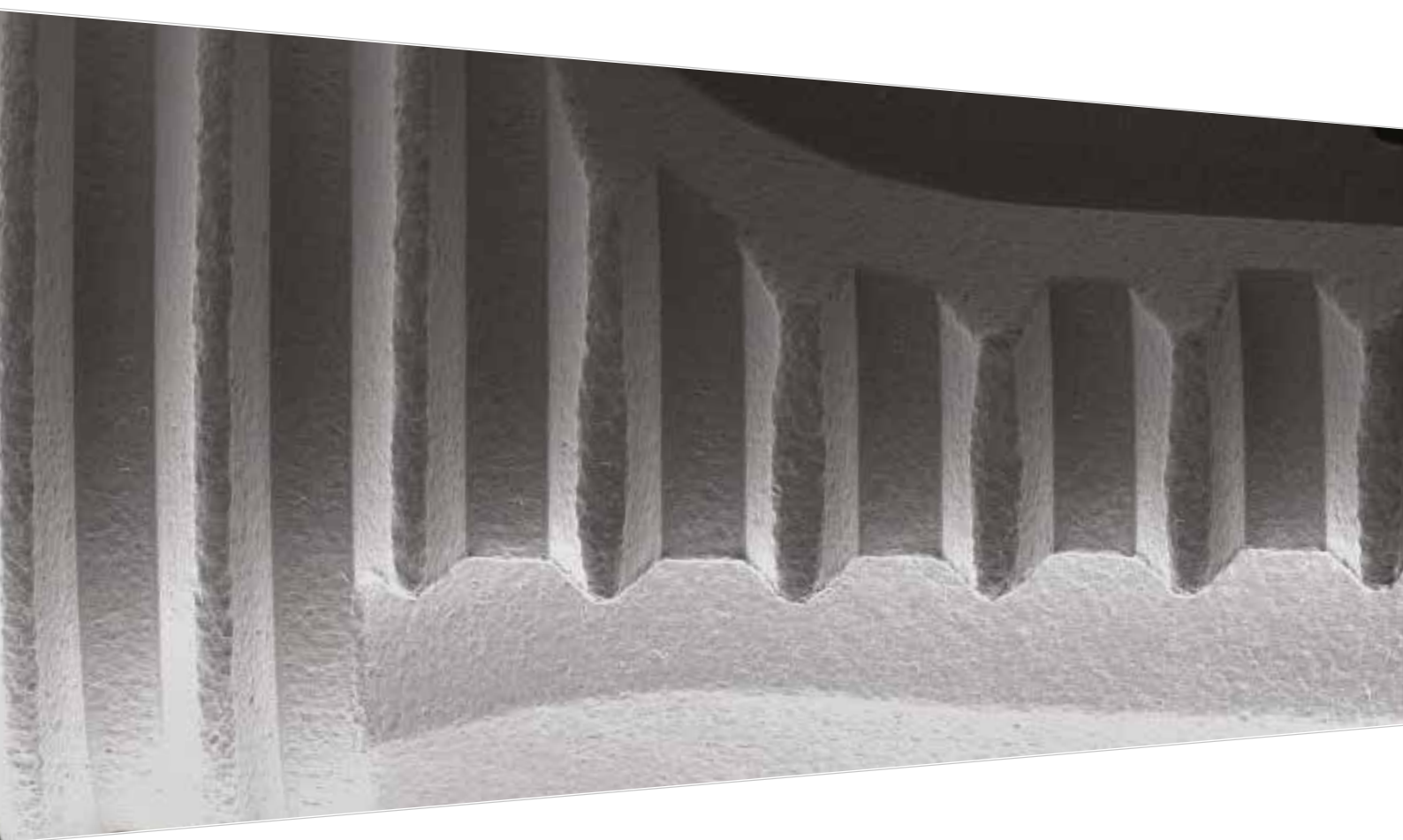

Multifunctional mounter:

The particular conformation of the Outlink² mounter allows it not only to act as a carrier for the transport and positioning of the implant in its site, but also as a transfer for taking the impression and as post.



The Outlink² implant system is suitable for:

- standard operating procedures involving the double or single surgical phase;
- immediate loading;
- post-extraction situations;
- guided regeneration protocols;
- Switching Platform.

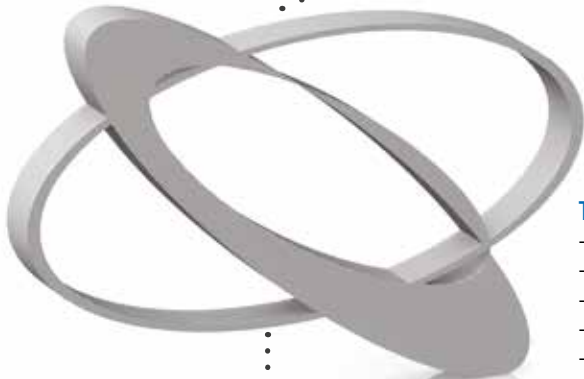

Outlink² Shorty:

The Outlink² implant range also includes a line of short fixtures, ideal in the case of small vertical bone dimension.



Wide range of fixtures:

The Outlink² implant system has a complete range of fixtures for diameters and heights, thus offering extremely versatile implant-prosthetic solutions. The Outlink² implants are available in diameters 3.30, 3.75, 4.10 (with the two different connections, standard and SP) and 5.00, and in all heights from h 5 mm to h 18 mm.





Cylindrical shape:

The implant body is cylindrical with a conical apical conformation for greater ease of insertion, and its external hexagon connection allows it to be used in different clinical situations.

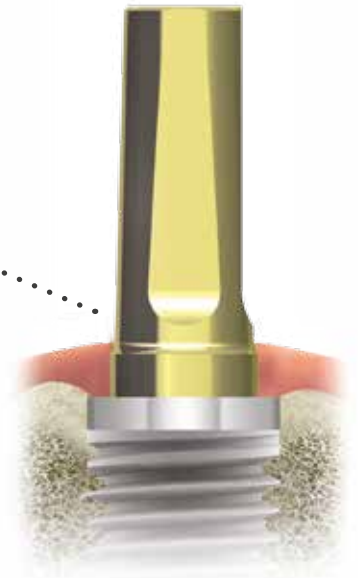

Switching Platform:

The geometrical characteristics of Outlink² connections enable them to be applied in Switching Platform protocols.



Completeness of prosthetic solution:

Ideal for both cemented and screwed prostheses, the external hexagon connection makes it particularly suitable in situation of severe disparallelism.



Scientific support:

The use of the Outlink² system is backed up by numerous publications which document its extreme versatility with over 10 years of clinical success.

Outlink² ø 3.30 implant

The Outlink² ø 3.30 implant has a platform with 2.40 mm external hexagon, 1.0 mm high and threading M 1.8, allowing any type of prosthetic restoration to be produced satisfactorily.

Due to their small diameter, ø 3.30 implants are ideal for implant-prosthetic rehabilitation when there is limited space between adjacent teeth, as in the case of single crowns in upper lateral incisor positions and in lower intraforaminal situations.*

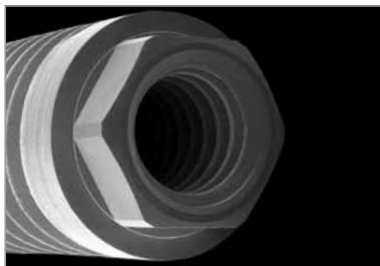

Stability with respect to disto-mesial and antero-posterior stress guaranteed by the external hexagon height of 1.00 mm. Resistant and particularly sturdy section despite its small diameter, thanks to the external hexagon connection.

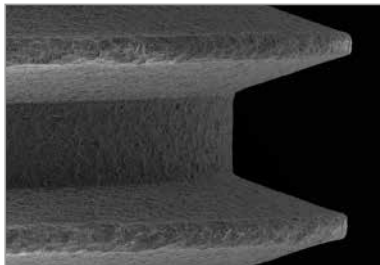

The thread of the implants has a pitch of 0.6 mm which facilitates screwing progress and limits bone trauma after application of the load.



Tapered apex with large discharge notches that give the implant excellent self-tapping properties; the fully threaded apex section considerably simplifies its insertion.

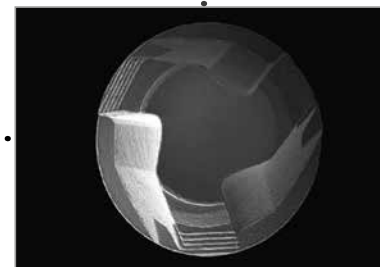
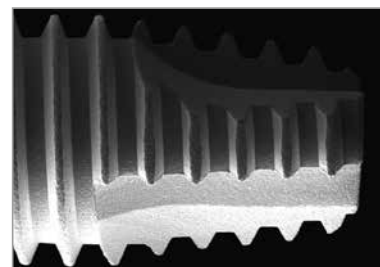

* They can also be used for the rehabilitation of single crowns at premolar level. In distal sectors they must be used exclusively for the rehabilitation of multiple fixed structures. They are also very useful in the case of total edentulism on thin mandibular crests where it is preferred not to carry out regeneration. In this case it is recommended to use at least 4 fixed implants with a bar.



Outlink² ø 3.75 and ø 4.10 implants

The Outlink² implant with prosthetic platform ø 4.10, with 2.70 mm standard hexagon 0.70 mm high and threading of M 2.0, is available both with a 4.10 mm neck and 3.75 mm spire and with a 4.10 mm neck and 4.10 mm spire.

Using the same platform (4.10 mm) it is possible to choose between two different spire diameters, 3.75 mm and 4.10 mm, depending on the available bone thickness.



The connection platform of Outlink² implants has an external hexagon that today is generally recognised as standard at world level.

The external connection makes them particularly suitable for operations in the case of multiple edentulism with severe disparallelism, as it considerably facilitates the phase of taking the impression and the subsequent insertion and removal of prostheses.

Outlink² ø 4.10 SP implant (Switching Platform)

The Outlink² ø 4.10 SP implant has a 4.10 mm prosthetic platform, a 2.40 mm hexagon 1.0 mm high with a threading of M 1.8, the same as those of the ø 3.30 implant. This characteristic allows the use of prosthetic components with diameter 3.30 mm, optimally performing the Switching Platform technique which takes advantage of the horizontal component of the biological width, thus minimising the loss of crestal bone.

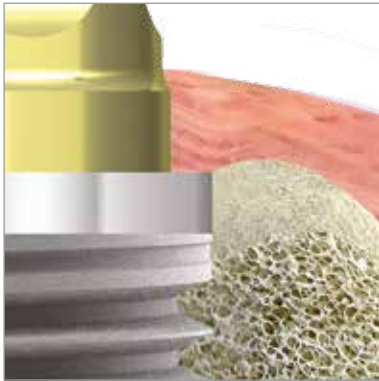

The Switching Platform is a prosthetic rehabilitation technique that requires the use of posts with a smaller diameter than the implant platform in order to improve the biomechanical distribution of the prosthetic load, but especially to distance the prosthetic connection from the cervical bone.

The portion of the connection platform not occupied by the prosthesis creates a supporting base for the connective tissue, thus stabilising the collagen fibres and in this way minimising bone reabsorption.



The Switching Platform technique is possible with ø 4.10 mm SP implants, using ø 3.30 mm prosthetic components on these implants.

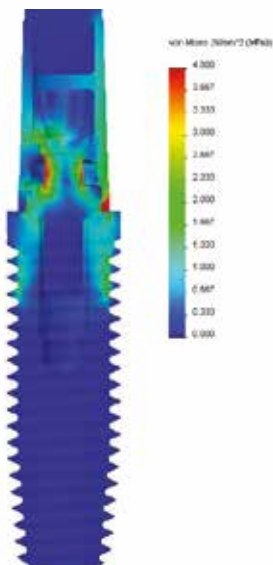

FEM analysis of Outlink² ø 4.10 mm implants with a ø 3.30 mm post according to the Switching Platform protocol.



Outlink² ø 5.00 implant

The Outlink² ø 5.00 presents a prosthetic platform with diameter 5.00 mm with 2.70 mm external hexagon, 0.70 mm high and threading M.20, the same as those of the standard 4.10 mm platform, which guarantees high precision and versatility. Outlink² ø 5.00 implants allow the application of the Switching Platform technique using ø 4.10 mm prosthetic components.

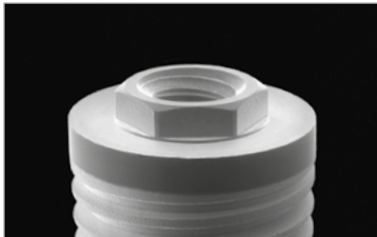

The 5.00 mm diameter of this implant makes it ideal for implant-prosthetic rehabilitation on thick bone crests. The external connection and the wide diameter of the spires give this implant extraordinary sturdiness and stability.

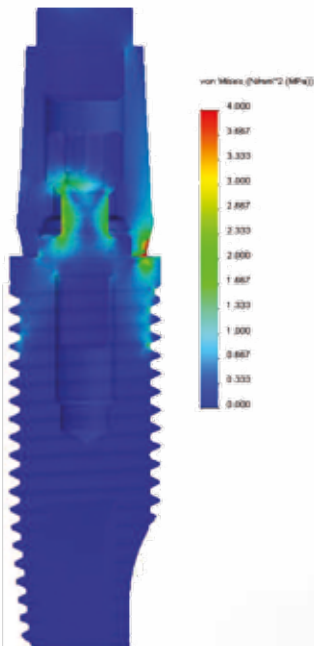

FEM analysis of Outlink² ø 5.00 mm implants with a ø 4.10 mm post according to the Switching Platform protocol.



The Switching Platform technique is possible with ø 5.00 mm implants, using ø 4.10 mm prosthetic components on these implants. This improves the preservation of the crestal bone.

Multifunctional mounter

The Outlink² implant has the mounter already assembled in the PMMA vial. As well as the traditional carrier function for the transport and positioning of the implant, the particular conformation of the Outlink² mounter, made in Gr.5 titanium, also allows it to be used as a transfer when taking the impression and as a post during prosthetic rehabilitation.



The retentive tabs can be cut easily, so that the mounter adapts to the morphology of the element to be prosthodontized and thus become a practical post.

The conical profile of the mounter facilitates insertion and removal of the crowns or of bridges, in the case of multiple structures.

The mounter is supplied already preassembled with the implant. The connecting screw is also available separately as a spare

The golden colour of the mounter/post guarantees maximum results as regards the aesthetic appearance of reconstructions.



..... The thickness of the mounter is such as to allow it to be reduced in height if necessary, or milled, and to create coulisses in the walls for repositioning the prosthesis.

The mounters with all diameters have two repositioning faces to guarantee a good non-rotational aspect while taking the impression.

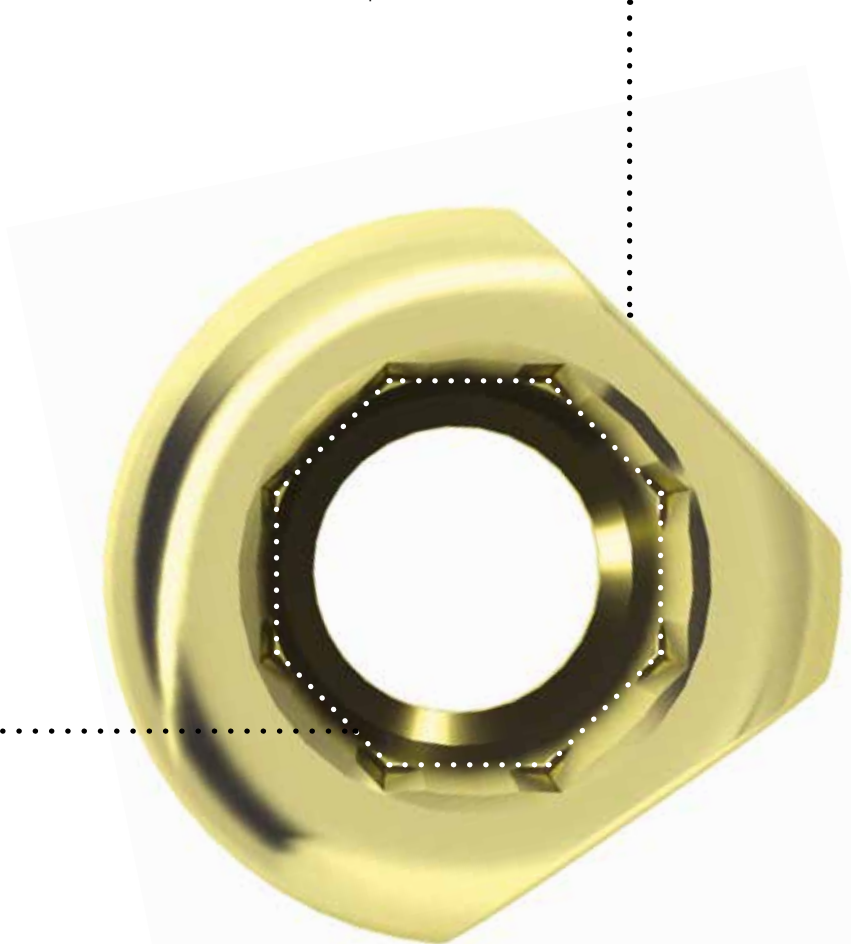

Practicality of the surgical procedure: the view of the mounter from above shows the conformation of the upper part, with an internal octagon, which allows it to be easily lifted by the driver and put into position.

Outlink² Shorty implants

Shorty Outlink² fixtures with height 5.0, 7.0 and 8.5 mm are available in the program; they can be used, according to the most recent clinical protocols, in all cases where there is small vertical bone dimension.

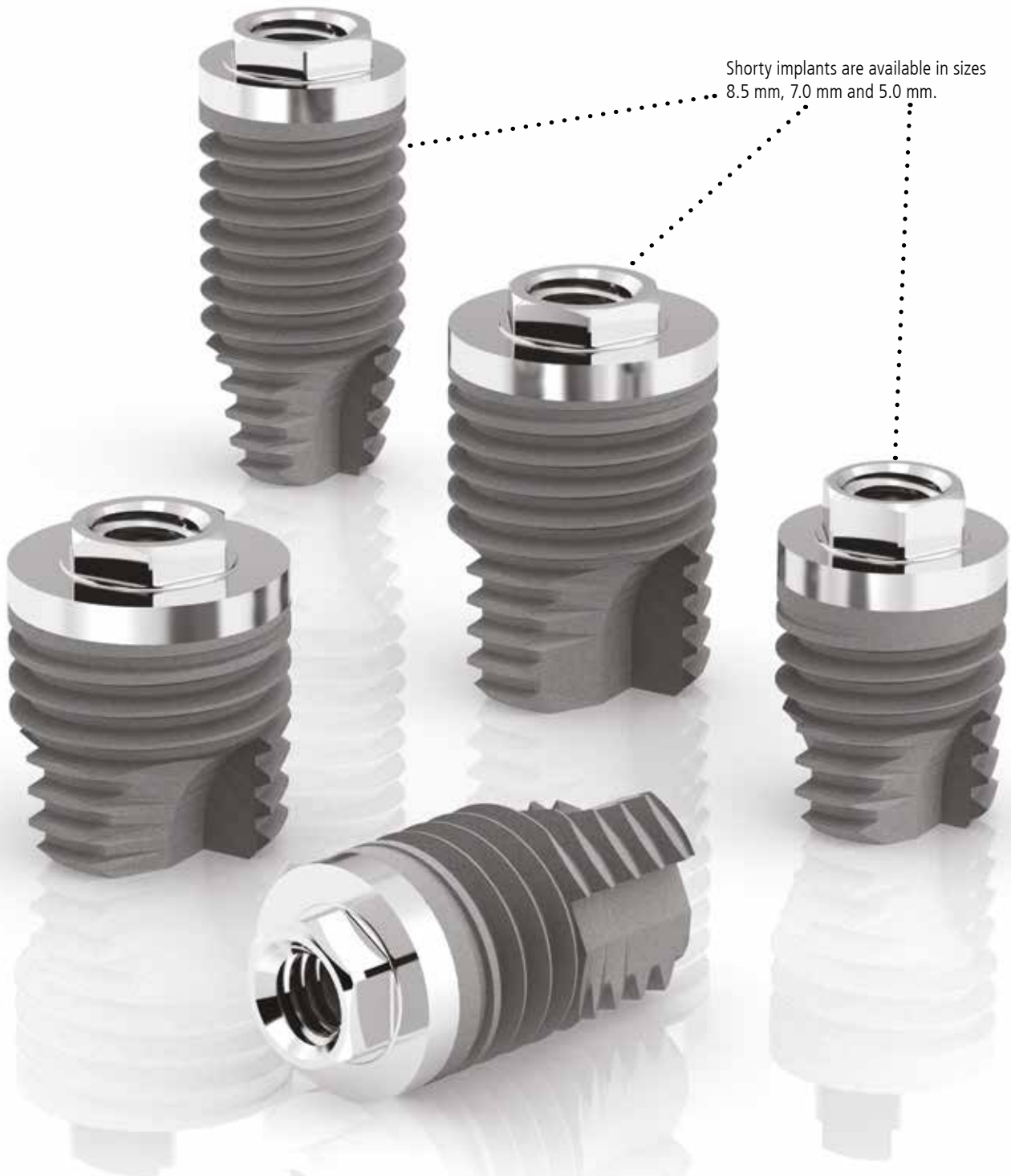

WARNING: Never use these implants for rehabilitating single crowns, but only as support posts combined with longer fixtures for multiple rehabilitations. It is also recommended to always use, whenever possible, implants with the largest diameter possible depending on the thickness of the crest.



In case of very short implants (5 mm and 7 mm), the apical tapering was redesigned to improve primary stability even further. Installing a prosthesis with the Switching Platform technique is recommended for these implants in order to preserve the already reduced vertical dimension of the crest as much as possible. This choice is necessary in Outlink² Shorty implants with a diameter of 4.10 mm because they have a 2.4 mm hexagon instead of the 2.7 mm standard hexagon (4.10SP platform).



Key to the implant codes

The implant codes are so-called “talking” codes, i.e. they allow easy identification of the piece. Below is a table showing how the talking codes work using Code E2-ZT-410-SP-115 as an example:

Type of implant E2- E2-	Surface ZT- ZT-	Diameter 410 410	Connection SP SP	Length 115 115
E2: Outlink ² implant	3S: Trisurface Surface ZT: ZirTi surface	330: 3.30 mm 375: 4.10 mm 410 - 410SP: 4.10 mm 500: 5.00 mm	SP: Switching Platform(e.g. 2.40 mm)	050: 5 mm 070: 7 mm 085: 8.5 mm 100: 10 mm 115: 11.5 mm 130: 13 mm 150: 15 mm
		<i>is the size of the diameter of the implant connection</i>		<i>refers to the length of the implant</i>

Table of colour codes

A colour code system has been defined in the Outlink² implant system for identifying the endosseous diameter of the implant (see table on page 44-45).

The colour code identifies:

- the transfers for taking an impression and the laboratory analogs;
- the final drills;
- the sequence on the surgical tray.

	ø 3.30	ø 3.75	ø 4.10	ø 4.10SP	ø 5.00
Colour code on the pack					

Surfaces

These studies have shown that the closer the roughness is to the size of the osteoblasts, the more influence it has on cell behaviour, causing the platelet activity to increase with respect to a smooth surface, thus accelerating the repair and osseointegration processes. The roughness is able to orient the cell layout, to influence their metabolism and proliferation, to differentiate osteoblasts and to modulate the production of extra-cellular matrix. These studies have led to the current development of the Outlink² implant surfaces: ZirTi (Zirconium Sand Blasted Acid Etched Titanium) and TriSurface.

ZirTi surface

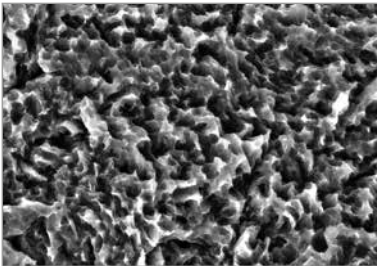

This is a surface in which the roughness is obtained with subtraction techniques by sand-blasting with zirconium oxide and acid-etching with mineral acids.

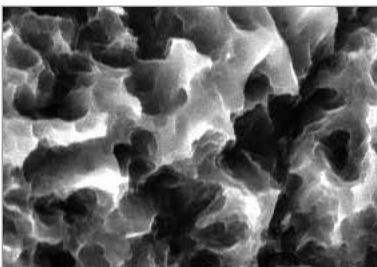

The roughness assumed by the surface of the implant body is an ideal situation for promoting osteoblastic proliferation and differentiation, as well as the formation and growth of bone tissue.

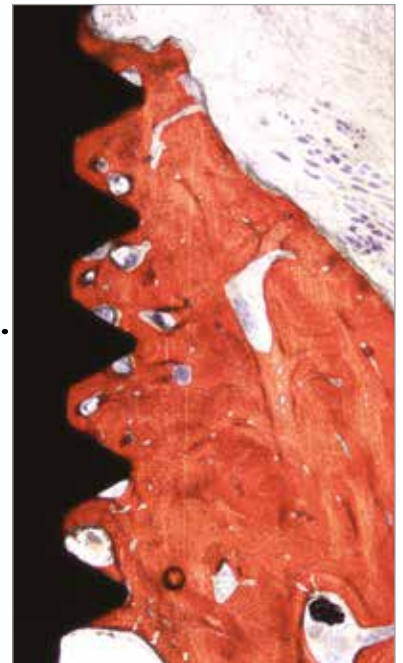

Histology showing vital mineralised bone in intimate contact with the ZirTi surface of an Outlink² implant. Osteons and areas of bone marrow can be seen.

Image and caption by kind permission of Dr Daniele Botticelli.

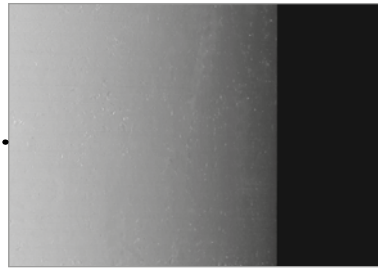

In both types of surface the collar is machined for 0.75 mm of the height.

TriSurface Surface

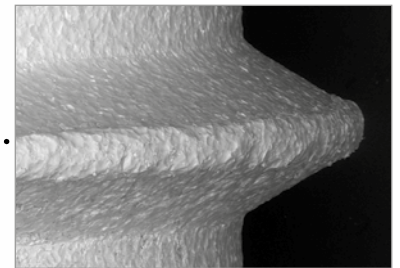

The implant with a TriSurface surface has a sandblasted coronal portion, in order to obtain an intermediate level of roughness that allows better control of any bacterial infections before they can degenerate into peri-implantitis.

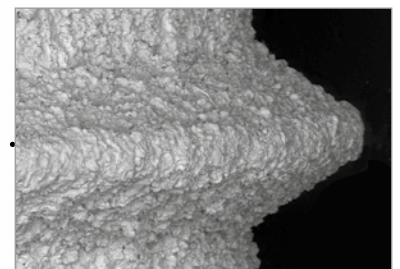

The middle apical portion of the body of the implant is coated with HRPS (High Roughness Plasma Spray) and has the maximum level of roughness that can be obtained, thus guaranteeing excellent primary stability even when the bone is only slightly mineralised, and significantly increasing the bone-implant contact surface.

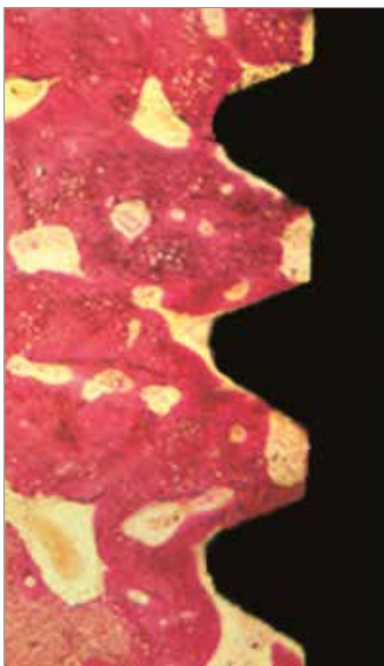

Histological image of the bone growth around an Outlink² implant with TriSurface surface.

*Il Circolo
Rivista Periodica di Odontostomatologia,
1: 13-20, 2004*

Cold plasma surface decontamination

The better the processes of passivation, cleaning and decontamination of an implant surface, the greater the presence of pure titanium able to come in contact with the bone. This proportionally increases the possibilities of osseointegration.

At the end of the surface treatments, the implants are subjected to a careful cleaning and decontamination process by means of cold plasma triggered in Argon after first being cleaned of the main processing residue with numerous washing cycles in specific solvents.

What is decontamination? It is the total removal of dirt, particle residue and Bioburden from the surface of the implants, carried out before sterilisation.

During the Argon treatment, the gas atoms are partially ionised, they acquire energy and "bombard" the surface of the fixture violently. This kind of "atomic sand-blasting" removes organic contaminants without leaving any traces or additional residuals.



Implant before the decontamination treatment.

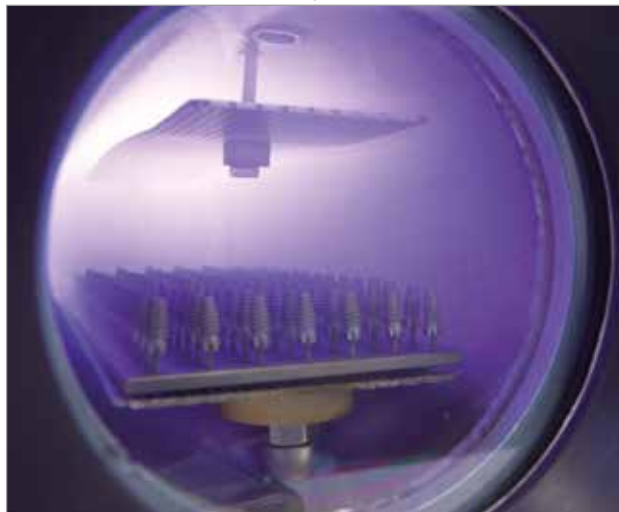

Working plasma reactor during surface decontamination of the implants.



Implant after the decontamination treatment.

As known, Argon is an inert gas that does not react with the titanium surfaces. The condition of surface decontamination is controlled regularly with randomised analyses of Bioburden residuals and a SEM visual examination on all the batches produced. This process activates the ionisation of the atoms on the surface of the titanium oxide which in turn increases the wettability of the fixture.



Implant packaging

The implants are packaged in PMMA vials in which they are held/housed in special titanium baskets that protect the surface of the fixture against possible recontaminations due to contact. All the materials comprising the packaging have been suitably tested to verify their suitability to sterilisation, preservation and medical use.



The blister packs containing the implants are packed in cardboard boxes which also contain the labels for the patient records reporting the details for traceability of the product (code and batch number).



The vials are contained in a special PETG blister pack sealed by a Tyvek cover, which guarantees sterility of the product for 5 years.



The mounter, assembled on every single implant, is visible, ready to be engaged by the special drivers.

The surgical cover screw, supplied with every single implant, is housed in a special compartment in the top of a blue cap made of LDPE which closes the vial. In turn, a small transparent lid in PMMA closes the blue cap.

Sterilisation











Sterilisation is the total elimination of the residual microbial load present on the implant after the decontamination and packing process, it is carried out with the use of beta rays. The sterilisation procedures are carried out in accordance with the UNI EN ISO 13485 and UNI EN ISO 9001 quality standards.

A beta ray sterilisation process was chosen because it has a variety of different advantages:

- the process occurs in a completely automatic way with computerised control of all the phases;
- the process is quick, reliable and extremely easy to repeat with safety and precision;
- the process is extremely eco-friendly, does not require the presence of radioactive sources and does not lead to the formation of toxic or radioactive products;
- beta rays are minimally invasive with regards to packaging due to the speed of the treatment. This guarantees preservation of the product's sterility over time (certified duration of 5 years).

THE RANGE









Outlink² implants

implant diameter	ø 3.30 mm	ø 3.75 mm	ø 4.10 mm	ø 4.10SP mm	ø 5.00 mm
mounter*	 E-MOU2-330	 E-MOU2-410	 E-MOU2-410	 E-MOU2-330	 E-MOU2-500
connecting screws	 VM-180	 VM-200	 VM-200	 VM-180	 VM-200
surgical cover screws**	 E-VT-330	 E-VT-410	 E-VT-410	 E-VT-330	 E-VT-500

* The mounters are sold preassembled with the implants. Both the mounters and the connecting screws (VM-180 and VM-200) are available on sale as individual spare parts. If the mounter is used as a post, the torque for tightening the screws is 20-25 Ncm.







** Each implant is sold with its own surgical cover screw. The surgical screws are also available on sale individually in a sterile pack and must be tightened to 10 Ncm.

Shorty implants

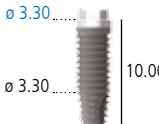
implant diameter	ø 3.30 mm	ø 3.75 mm	ø 4.10 mm	ø 4.10SP mm	ø 5.00 mm
5.00	-	-	-	 5.00	 5.00
ZirTi TriSurface				E2-ZT-410SP-050	E2-ZT-500-050
7.00	-	-	-	 7.00	 7.00
ZirTi TriSurface				E2-ZT-410SP-070	E2-ZT-500-070
8.50	-	 8.50	 8.50	 8.50	 8.50
ZirTi TriSurface		E2-ZT-375-085 E2-3S-375-085	E2-ZT-410-085 E2-3S-410-085	E2-ZT-410SP-085 E2-3S-410SP-085	E2-ZT-500-085 E2-3S-500-085

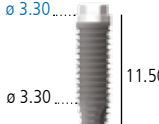

Standard implants

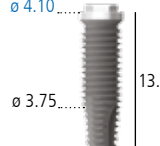
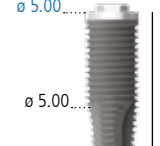
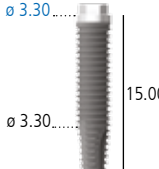
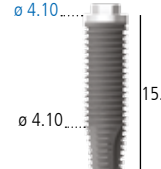
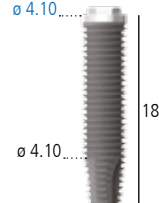
implant diameter	ø 3.30 mm	ø 3.75 mm	ø 4.10 mm	ø 4.10SP mm	ø 5.00 mm
10.00					
ZirTi TriSurface	E2-ZT-330-100 E2-3S-330-100	E2-ZT-375-100 E2-3S-375-100	E2-ZT-410-100 E2-3S-410-100	E2-ZT-410SP-100 E2-3S-410SP-100	E2-ZT-500-100 E2-3S-500-100
11.50					
ZirTi TriSurface	E2-ZT-330-115 E2-3S-330-115	E2-ZT-375-115 E2-3S-375-115	E2-ZT-410-115 E2-3S-410-115	E2-ZT-410SP-115 E2-3S-410SP-115	E2-ZT-500-115 E2-3S-500-115
13.00					
ZirTi TriSurface	E2-ZT-330-130 E2-3S-330-130	E2-ZT-375-130 E2-3S-375-130	E2-ZT-410-130 E2-3S-410-130	E2-ZT-410SP-130 E2-3S-410SP-130	E2-ZT-500-130 E2-3S-500-130
15.00					-
ZirTi TriSurface	E2-ZT-330-150 E2-3S-330-150	E2-ZT-375-150 E2-3S-375-150	E2-ZT-410-150 E2-3S-410-150	E2-ZT-410SP-150 E2-3S-410SP-150	-
18.00	-	-		-	-
ZirTi TriSurface	-	-	E2-ZT-410-180	-	-

Surgical kit

The Outlink² surgical kit has been designed and made to offer ease of use and immediate placing in the sequence of instruments*. The instruments, all made of stainless steel, have their codes screen-printed on the tray to allow the user to identify each instrument more easily and to put it back after the cleansing and cleaning phases, with the aid of a colour code system that traces the suitable surgical procedures for the various implant diameters. The Outlink² surgical kit is also supplied with the templates for the graphic representation of the implant measurements to allow choosing the most suitable implant diameters and lengths by means of radiographic or tomographic analyses



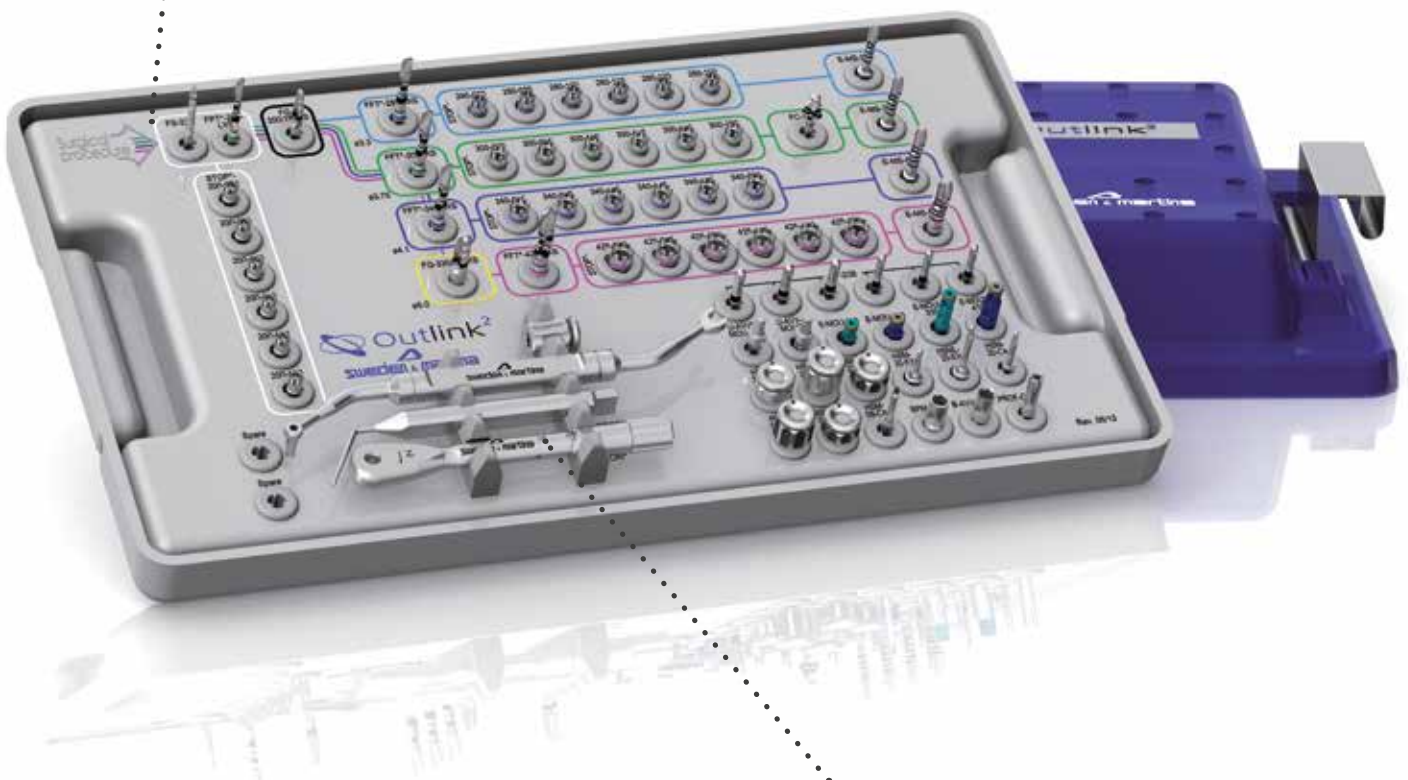

The kit consists of a practical box in Radel with a surgical tray inside that is set-up to hold the instruments according to a guided procedure. The sequences of use of the instruments are indicated by coloured marks.



A practical ratchet is also included that acts as a dynamometric key for checking the closing torque of the prosthetic screws and as a surgical key for inserting the implants. The ratchet has a very small head, making it easy to use even in distal sectors.

*Please note: to guarantee maximum duration of the surgical and prosthetic instruments, it is advisable to follow the recommended cleansing and sterilisation procedures.



code	description
 <p data-bbox="225 479 341 510">ZOUTLINK2*</p>	Surgical kit complete with all the instruments necessary for Outlink² implants
 <p data-bbox="240 719 325 750">OUT-KIT*</p>	Radel instrument tray for Outlink² implants
 <p data-bbox="225 869 344 900">GROMMET-3</p>	Kit with 5 spare silicon supports for surgical trays, for drills or instruments with right-angle shanks
 <p data-bbox="225 1019 344 1050">GROMMET-4</p>	Kit with 5 spare silicon supports for surgical trays, for instruments fitted with connection hexagon
 <p data-bbox="225 1164 344 1196">GROMMET-5</p>	Kit with 5 spare silicon supports for surgical trays, for digital or handheld instruments

* The abbreviations ZOUTLINK2* and OUT-KIT* are followed by a letter and number that indicate the revision of the kit. The contents of the Surgical Kit can be updated and varied according to the most effective and innovative surgical techniques.

OneBox²

The OneBox² surgical kit was created to meet the needs of surgeons who carry out a large number of implant operations and who therefore want to have a compact kit equipped essentially with all that is needed only for the surgical phase.





The OneBox² is a compact kit that is easy to carry, containing the surgical instruments strictly necessary for inserting Outlink2 implants.



The bone taps are present in the kit in the version with right-angle attachment.

This kit contains space for an additional series of alternative drills, which the surgeon may wish to choose and use depending on his experience.







code	description
 ZEONEBOX*	OneBox ² surgical kit
 EONEBOX-KIT*	Instrument tray for OneBox ²
 GROMMET-CA-1	Kit with 5 spare silicon supports for surgical trays, for drills or instruments with right-angle shanks
 GROMMET-CA-2	Kit with 5 spare silicon supports for surgical trays, for instruments fitted with connection hexagon

* The words ZEONEBOX* and EONEBOX-KIT* are followed by a letter and a number that indicate the revision of the kit. The contents of the kit can be updated and varied according to the most effective and innovative surgical techniques

WARNING: OneBox² does not contain drill depth stops or prosthetic drivers, but it contains all the drivers in the one-piece digital version and the right-angle version, which are much more practical during surgical procedures.



code	description
 <p>ZSCREW*</p>	Complete Screw Kit
 <p>SCREW-TRAY*</p>	Instrument tray for Screw Kit
 <p>GROMMET-CA-1</p>	Kit with 5 spare silicon supports for surgical trays, for drills or instruments with right-angle shanks
 <p>GROMMET-CA-2</p>	Kit with 5 spare silicon supports for surgical trays, for instruments fitted with connection hexagon

* The abbreviations ZSCREW* and SCREW-TRAY* are followed by a letter and a number that indicate the revision of the kit. The contents of the kit can be updated and varied according to the most effective and innovative surgical techniques.

Initial, intermediate and countersink drills

All Sweden & Martina drills are made of stainless steel with high resistance to corrosion and wear. The extreme accuracy of design and production allows use completely free from vibrations and oscillations.

Precision drill: very sharp and precise, it facilitates the opening of the implant site especially in the case of very hard cortical bone.

Intermediate drills: the shape with progressive diameter of the 2 intermediate drills allows gradual expansion of the bone when using a drill with a diameter much larger than the previous one, so as to reduce bone stress to a minimum.



Pilot drill: the different heights of the laser markings allow better visibility in the surgical field and greater ease of recognition of the different depths during use.

Countersink drill: ideal for preparing the coronal part of the site in the case of implants with a prosthetic platform wider than the diameter of the spires.



initial drill, intermediate drills and countersink drill

kit

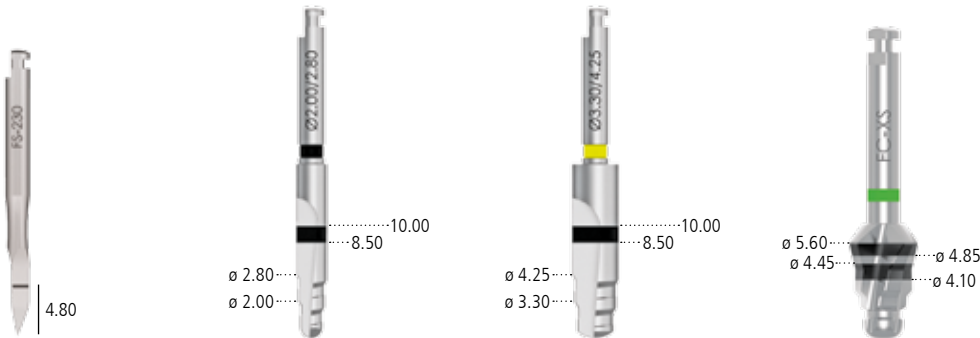

ZOUTLINK2*
ZEONEBOX*

FS-230
precision drill

FG-200/280XS
intermediate drill
ø 2.00 - 2.80 mm

FG-330/425XS
intermediate drill
ø 3.30 - 4.25 mm

FC-XS
countersink drill

pilot drill

pilot drill stops

kit

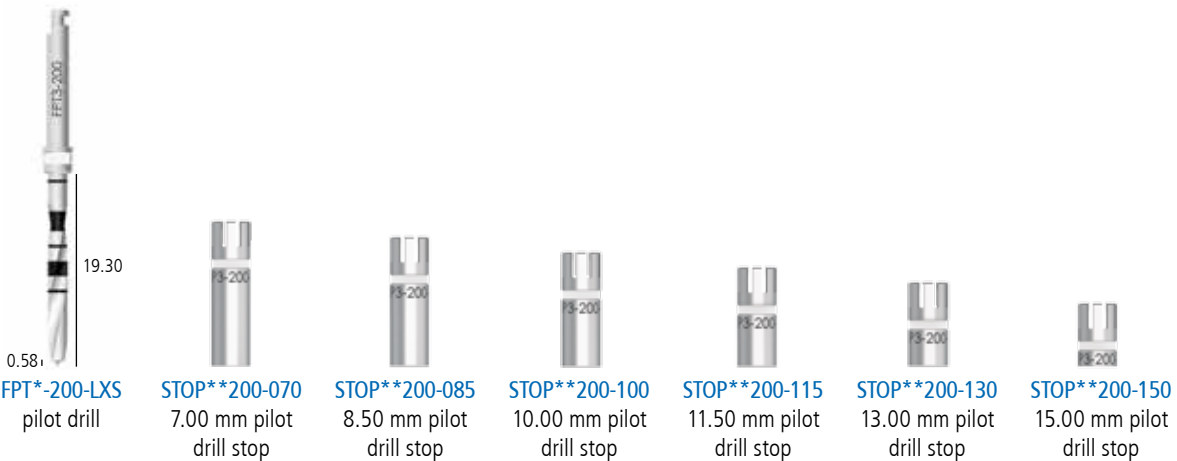

ZOUTLINK2*
ZEONEBOX*

FPT*-200-LXS
pilot drill

STOP200-070**
7.00 mm pilot
drill stop

STOP200-085**
8.50 mm pilot
drill stop

STOP200-100**
10.00 mm pilot
drill stop

STOP200-115**
11.50 mm pilot
drill stop

STOP200-130**
13.00 mm pilot
drill stop

STOP200-150**
15.00 mm pilot
drill stop

* The word STOP is followed by a number indicating the revision of the accessory. The stops are included only in the ZOUTLINK2* surgical kit.

Lt: Total length of the working part, including the tip.
Lp: Length of the tip. This measurement must be calculated in addition to the length of the preparation hole.

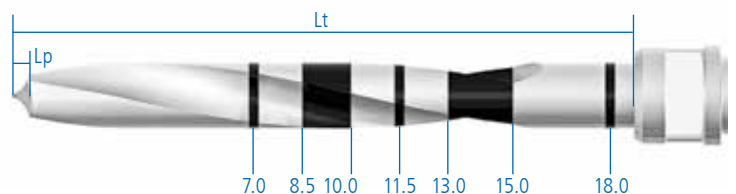

Please note: The letters FPT are followed by a number (2, 3) indicating the length of the drill shank: 2 indicates a length of 12.5 mm, 3 indicates a length of 14 mm. All the STOP2 and STOP3* are functional to any of these batches.

Please note: The initial drills (FPT*) and the final drills (FFT*, shown on the following page) always make a hole longer than the implant that is to be inserted. The oversizing (Lp) is equal to the height of the tip of the drill that is being used.

Final drills and stops

Also made of stainless steel with high resistance to corrosion and wear, Outlink² final drills present a number of cutting edges proportional to the hole diameter, so as to allow a continuous and homogeneous cutting movement and greater instrument stability during operation. All this enables high-precision implant preparations to be obtained, with consequent ease in inserting the implant.































The stops are inserted from the tips of the drills, with great ease and speed.

The coloured rings make it easy to recognise the dedicated instruments for each implant diameter.

The surgical drills have a spiral designed to allow the operator better control of the forward movement and better centring during the drilling phase.



implant diameter	ø 3.30 mm	ø 3.75 mm	ø 4.10 mm ø 4.10SP mm	ø 5.00 mm	kit
drills**	 0.81 FFT*-280-LXS 19.60	 0.87 FFT*-300-LXS 19.60	 0.95 FFT*-340-LXS 19.70	 1.23 FFT*-425-LXS 20.00	ZOUTLINK2* ZEONEBOX*
	 STOP*-280-070	 STOP*-300-070	 STOP*-340-070	 STOP*-425-070	ZOUTLINK2*
	 STOP*-280-085	 STOP*-300-085	 STOP*-340-085	 STOP*-425-085	ZOUTLINK2*
	 STOP*-280-100	 STOP*-300-100	 STOP*-340-100	 STOP*-425-100	ZOUTLINK2*
stop	 STOP*-280-115	 STOP*-300-115	 STOP*-340-115	 STOP*-425-115	ZOUTLINK2*
	 STOP*-280-130	 STOP*-300-130	 STOP*-340-130	 STOP*-425-130	ZOUTLINK2*
	 STOP*-280-150	 STOP*-300-150	 STOP*-340-150	 STOP*-425-150	ZOUTLINK2*

***Please note:** The letters FFT are followed by a number (2, 3) indicating the length of the drill shank: 2 indicates a length of 12.5 mm, 3 indicates a length of 14 mm. All the STOP2 and STOP3* are functional to any of these batches.

****Please note:** The drills always make a hole that is longer than the implant to be inserted. The oversizing (Lp) is equal to the height of the tip of the drill that is being used. See image on page 27.

Bone taps

Outlink² implants are self-tapping implants with excellent cutting and insertion capabilities. However, the use of a bone tap is recommended in all cases where the type of bone requires it. The absence of tapping in cases where this is recommended may lead to problems later when inserting the implant. They are available both with right-angle shank and with a connector for dynamometric ratchet.

Standard bone tap: to be used with the dynamometric ratchet, gives great sensitivity during use.

Short bone tap: to be used with the dynamometric ratchet, it is very useful in distal sectors.

Right-angle bone tap: for better control of the inserting axis and more uniform preparation.





implant diameter	ø 3.30 mm	ø 3.75 mm	ø 4.10 mm ø 4.10SP mm	ø 5.00 mm	kit
standard bone taps					ZOUTLINK2*
	E-MS-330	E-MS-375	E-MS-410	E-MS-500	
right-angle bone taps					ZEONEBOX*
	E-MS-330-CA	E-MS-375-CA	E-MS-410-CA	E-MS-500-CA	
short bone taps*					-
	E-MSC-330	E-MSC-375	E-MSC-410	E-MSC-500	

* Please note: short bone taps are not included in any surgical kit.

Osteotomes

A set of steel osteotomes is available, useful for maxillary sinus floor elevation via the crestal bone and bone expansion protocols. The laser-etched codes on the handles show the diameter and height of the corresponding implant, so as to facilitate recognition of the correct surgical sequence.

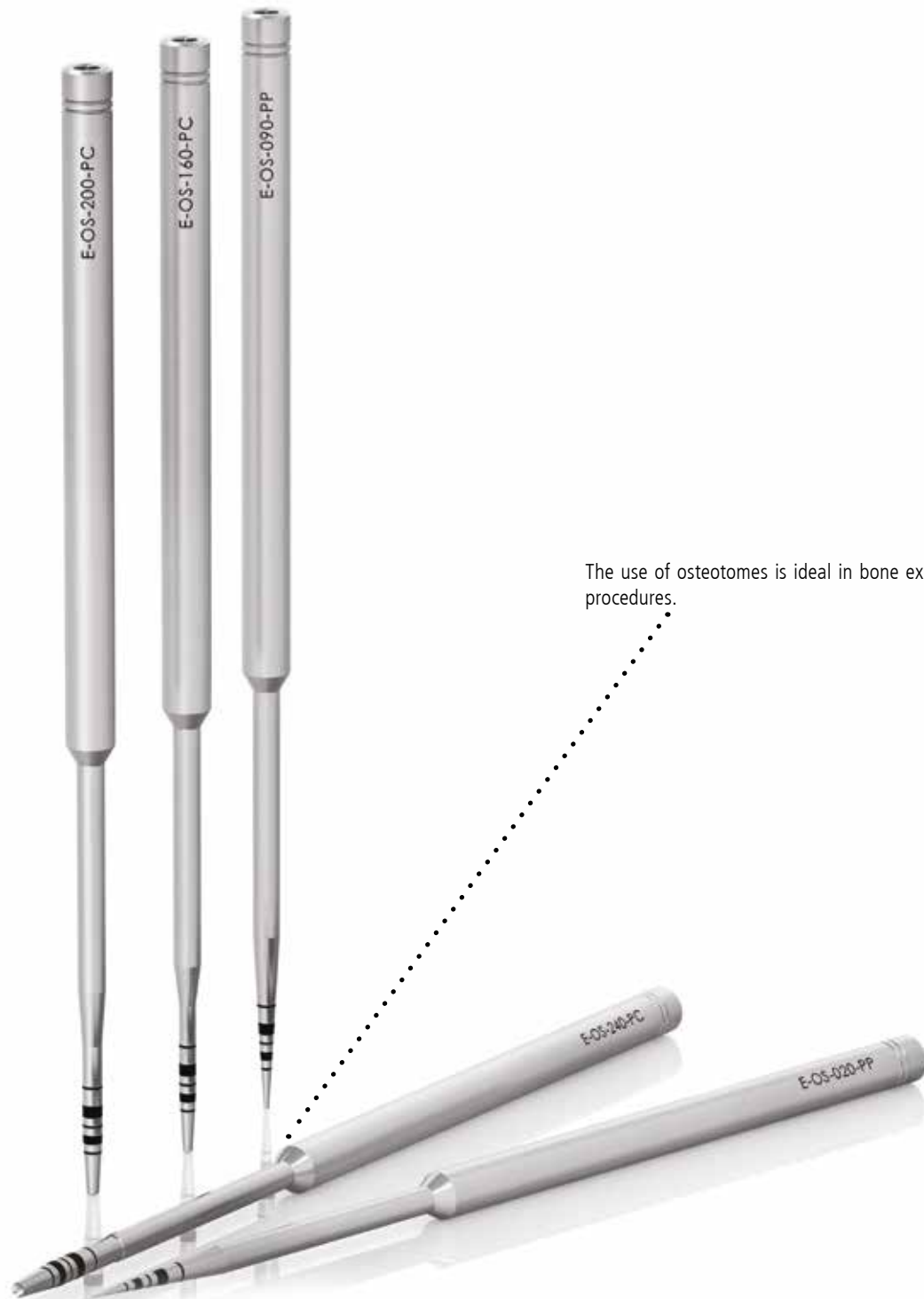

The use of osteotomes is ideal in bone expansion procedures.



code	description
E-OS-020-PP	Outlink ² Osteotome ø 0.20, flat tip
E-OS-090-PP	Outlink ² Osteotome ø 0.90, flat tip
E-OS-160-PC	Outlink ² Osteotome ø 1.60, concave tip
E-OS-200-PC	Outlink ² Osteotome ø 2.00, concave tip
E-OS-240-PC	Outlink ² Osteotome ø 2.40, concave tip

All measurements are given in mm, unless indicated otherwise.

Drills for distal sectors

As an option, shorter drills are available that are very practical in distal sectors with limited oral opening. They come in a wide range of diameters and are also useful for preparations in extremely compact bone where, in the most coronal portion, you want to widen the preparation diameter by 0.10 mm with respect to the size of the standard drills to facilitate the insertion of the implants. On the other hand, in low-density bone they can be used to under-prepare the implant site so as to obtain optimum primary stability.



The drills have etched depth lines from 7 to 15 mm.





Cylindrical drills

ø 2.00 mm



FFT5-200-LXS*
Cylindrical drill ø 2.00 mm

ø 2.80 mm

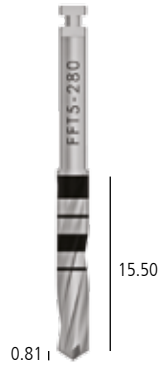

FFT5-280-LXS*
Cylindrical drill ø 2.80 mm

ø 2.90 mm

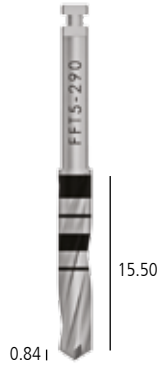

FFT5-290-LXS*
Cylindrical drill ø 2.90 mm

ø 3.00 mm

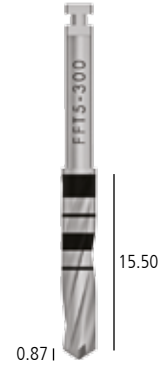

FFT5-300-LXS*
Cylindrical drill ø 3.00 mm

ø 3.20 mm

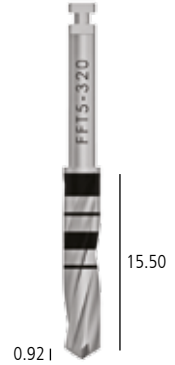

FFT5-320-LXS*
Cylindrical drill ø 3.20 mm

ø 3.30 mm

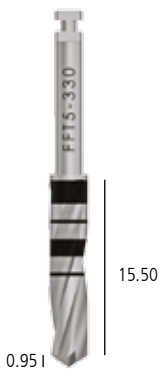

FFT5-330-LXS*
Cylindrical drill ø 3.30 mm

ø 3.40 mm



FFT5-340-LXS*
Cylindrical drill ø 3.40 mm

ø 3.60 mm



FFT5-360-LXS*
Cylindrical drill ø 3.60 mm

ø 4.25 mm



FFT5-425-LXS*
Cylindrical drill ø 4.25 mm

ø 4.45 mm







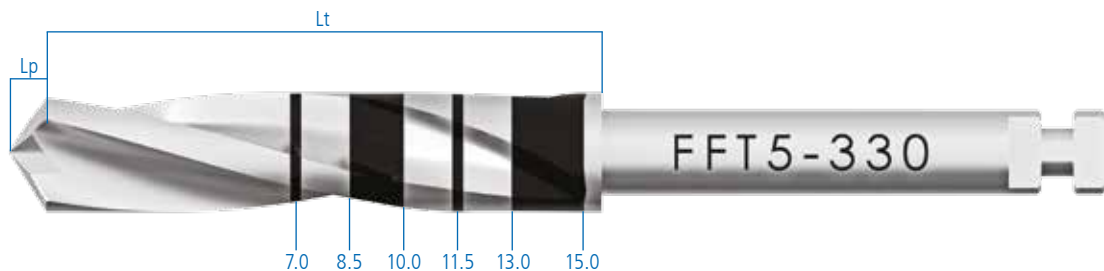



FFT5-445-LXS*
Cylindrical drill ø 4.45 mm

* The drills for distal sectors are without irrigation and are not included in any surgical kit. They cannot be used with depth stops





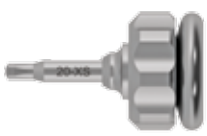
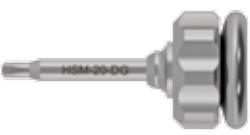



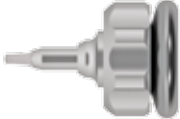
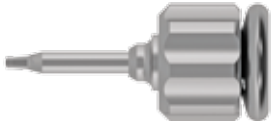

Please note: The drills always make a hole that is longer than the implant to be inserted. The oversizing (Lp) is equal to the height of the tip of the drill that is being used.











Drivers and Screwdrivers

code	description	kit
 U-AW3-MOU-CA	Octagonal driver with right-angle attachment for Outlink ² implant mounter	ZOUTLINK2*
 U-AVV-MOUC	Short octagonal driver for Outlink ² implant mounter	ZOUTLINK2*
 AVV-CA-DG-EX	Hand knob for hand use of drivers, bone taps and drivers with right angle shank and with hexagonal connection for torque-control ratchet	ZEONEBOX*
 HSM-20-EX	Driver for connecting screws, with connector for dynamometric ratchet or digital connector, short	ZOUTLINK2* ZSCREW*
 HSML-20-EX	Driver for connecting screws, with connector for dynamometric ratchet or digital connector, long	ZOUTLINK2* ZSCREW*
 HSMXL-20-EX	Driver for connecting screws, with connector for dynamometric ratchet or digital connector, extra long	ZSCREW*
 HSMXS-20-DG	Driver for surgical connecting screws, digital, extra short	ZOUTLINK2* ZEONEBOX* ZSCREW*
 HSM-20-DG	Driver for connecting screws, digital, short	ZOUTLINK2* ZEONEBOX* ZSCREW*
 HSML-20-DG	Driver for connecting screws, digital, long	ZOUTLINK2* ZEONEBOX* ZSCREW*











code	description	kit
 HSMXS-09-DG	Driver for surgical cover screws, digital, extra short	ZOUTLINK2* ZEONEBOX*
 HSM-09-DG	Driver for surgical cover screws, digital	ZOUTLINK2* ZEONEBOX*
 HSM-20-CA	Driver for connecting screws, with right-angle shank	ZOUTLINK2* ZEONEBOX* ZSCREW*
 HSM-09-CA	Driver for surgical cover screws, with right-angle shank	ZOUTLINK2* ZEONEBOX*
 AVV2-ABUT	Driver for standard abutments and for straight P.A.D. abutments	ZSCREW*
 BASCC-EX	Driver for ball attachments, with connector for dynamometric ratchet or digital connector	ZSCREW*
 8926-SW	Short driver in Gr. 5 titanium for screwing the Locator Abutments. The driver is compatible with the Outlink² system's dynamometric ratchet	ZSCREW*
 8927-SW	Long driver in Gr. 5 titanium for screwing the Locator Abutments. The driver is compatible with the Outlink² system's dynamometric ratchet	ZSCREW*
 PAD-CAR	Carrier for transferring angled P.A.D. abutments into the oral cavity, sterilisable and reusable. It must be fixed to the abutments with the screw PAD-VTRAL-140	ZSCREW*

Accessories

code	description	kit
 B-AVV-CA3	Mechanical adapter with right-angle shank for instruments with hexagonal connector	ZOUTLINK2* ZEONEBOX* ZSCREW*
 BPM-15	Extension for bone taps, mounters, drivers and manual drivers, with hexagonal connector for dynamometric key	ZOUTLINK2* ZEONEBOX*
 AVV3-MAN-DG	Hand knob for bone taps, mounters, drivers and manual drivers	ZOUTLINK2* ZSCREW*
 ORING180-088	Kit with 5 spare o-rings for all accessories with hexagonal connector for dynamometric key	-
 CRI5-KIT	Kit composed of a ratchet, which can be used in dynamometric or fixed mode, and accessories for quick torque adjustment and periodic maintenance (Allen wrench and lubricant). The ratchet has torque limits from 10 to 70 Ncm, with adjustment lines at 10-20-25-30-35-50-70 Ncm. (Supplied with the Outlink ² surgical kit)	ZOUTLINK2* ZEONEBOX* ZSCREW*
 PP-2/28	Parallelism pin Ø 2.00 and 2.80 mm	ZOUTLINK2* ZEONEBOX*
 PROF3	Depth gauge	ZOUTLINK2*
 CMD	Mounter stop key	ZOUTLINK2* ZEONEBOX*
 E2-CM	Mounter stop key	ZOUTLINK2* ZEONEBOX*
 PROF-CAL2	Extension for surgical drills	ZOUTLINK2* ZEONEBOX*

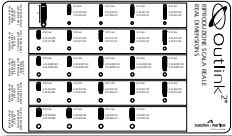

code	description	kit
 E-MOU-330	Short mounter Ø 3.30	ZOUTLINK2*
 E-MOU-410	Short mounter Ø 4.10	ZOUTLINK2*
 E-MOUL-330	Long mounter Ø 3.30	ZOUTLINK2*
 E-MOUL-410	Long mounter Ø 4.10	ZOUTLINK2*
 E-PAD-PS410-L	Bone profiler for levelling irregular bone crest, with wide flaring	-
 E-PAD-PS410-S	Bone profiler for levelling irregular bone crest, with narrow flaring	-
 E-L100	X-ray template for Outlink² implants (real dimensions)	ZOUTLINK2* ZEONEBOX*
 E-L120	X-ray template for Outlink² implants (dimensions increased by 20%)	ZOUTLINK2* ZEONEBOX*
 E-L130	X-ray template for Outlink² implants (dimensions increased by 30%)	ZOUTLINK2* ZEONEBOX*

Shorty drilling kit

The implant site of the specific Shorty implants with lengths of 5.0, 7.0 and 8.5 mm can be prepared with the drills contained in the standard surgical kits; however, the drills in these kits require an over-preparation connected to the measurement of the drill tip. On the other hand, the choice of a short implant is generally connected to the lack of available bone height in the implant site, so it would be preferable not to have to engage a working thickness with the tip of the drill, but instead to lodge a longer implant. For this reason, a drilling kit was created to enable preparing the sites for Shorty implants with a height of 5.7, and 8.5 mm and very short tip where a portion of over-preparation is not considered necessary. The Shorty drills allow dedicating the entire bone available to lodging the implant, without any waste. They also have the advantage of being shorter than the standard drills (24.85 mm instead of 35 mm). This important feature makes it possible to use these instruments even in case of difficult to reach distal sectors or small oral openings.



The kits contain two short parallelism pins, which are very handy in distal sectors.



All the instruments in the Shorty Drilling Kit are also available individually as spare parts.

The colour codes of the implant diameters facilitate the choice of the instruments.



code	description
	Drilling kit for short implants
ZSHORTY*	
	Empty tray in Radel
SHORTY-KIT*	
	Kit with 5 spare silicon supports for surgical trays, for drills or instruments with right-angle shanks
GROMMET-CA-1	

* The abbreviations ZSHORTY* and SHORTY-KIT* are followed by a letter and a number that indicate the revision of the kit. The contents of the kit can be updated and varied according to the most effective and innovative surgical techniques.

Instruments contained in the Shorty Drilling Kit

Shorty pilot drill

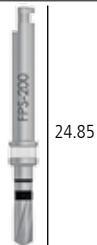

FPS-200
Shorty pilot drill

Shorty pilot drill stops



STOPS-200-050
5.00 mm stop
for Shorty pilot drill



STOPS-200-060
6.00 mm stop
for Shorty pilot drill



















STOPS-200-070
7.00 mm stop
for Shorty pilot drill

code	description	diameter
 FGS-200/300	Short guide drill	2.00/2.50/3.00
 FGS-340/425	Short guide drill	3.40/3.80/4.25
 FGS-425/540*	Short guide drill	4.25/4.80/5.40
 PPS-2/3	Parallelim pin for short drills with depth lines at 5.00, 6.00 and 7.00	2.00/3.00

* Intermediate drill dedicated to other Sweden & Martina implant systems.



	ø 3.75 mm	ø 4.10 mm ø 4.10SP mm	ø 5.00 mm	ø 6.00 mm
drills	 24.85 FFS-300	 24.85 FFS-340	 24.85 FFS-425	 24.85 FFS-540*
	 STOPS-300-050	 STOPS-340-050	 STOPS-425-050	 STOPS-540-050*
stop	 STOPS-300-060	 STOPS-340-060	 STOPS-425-060	 STOPS-540-060*
	 STOPS-300-070	 STOPS-340-070	 STOPS-425-070	 STOPS-540-070*

* Drills and stops with diameter 5.40 mm for other Sweden & Martina implant systems are also available in the Drilling Kit.

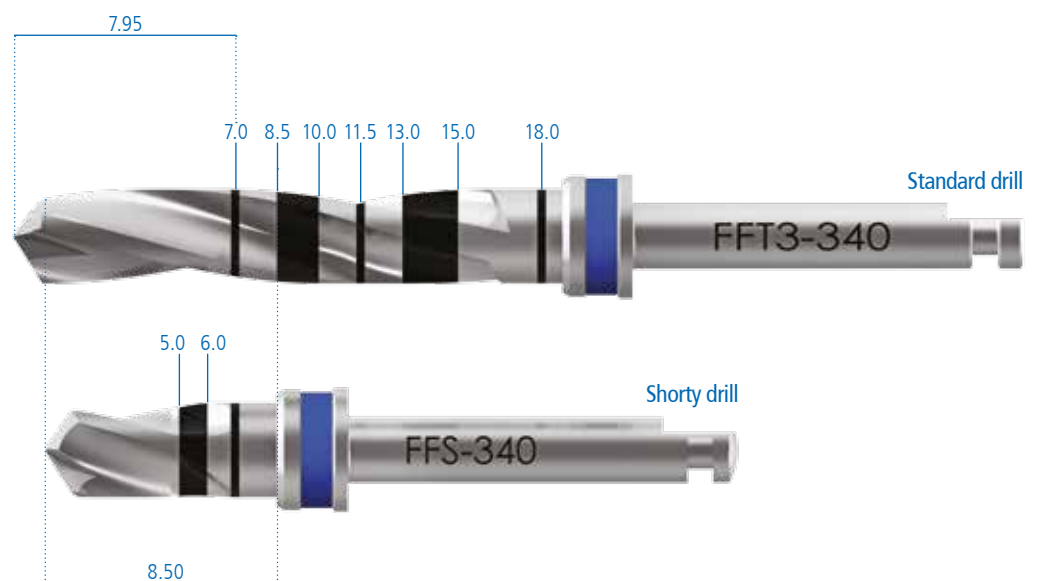

Please note: remember that the drills in the Drilling Kit do not over-prepare the surgical site. The working lengths include the portion related to the conical tip of the drill.

GUIDE TO THE CHOICE OF PROSTHETIC SOLUTIONS

implant diameter

Ø 3.30 mm

Ø 3.75 mm



label with colour code on the pack



final drills



FFT*-280-LXS



FFT*-300-LXS

connecting screw



VM-180



VM-200

open tray transfer



E-TRA-330-RIT



E-TRAR-330-RIT



E-TRAR-410-RIT

screw for open tray transfer



VTRA-180



VTRA-200

closed tray transfer



E-TRARS-330



E-TRARS-410

screw for closed tray transfer



E-VTRAS-180



E-VTRAS-200

analog



E-ANA-330



E-ANA-410



Ø 4.10 mm

Ø 4.10SP mm

Ø 5.00 mm



FFT*-340-LXS



FFT*-340-LXS



FFT*-425-LXS



VM-200



VM-180



VM-200



E-TRAR-410-RIT



E-TRAR-330-RIT



E-TRAR-410-RIT



E-TRAR-500-RIT



VTRA-200

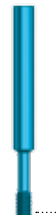

VTRA-180



VTRA-200



E-TRARS-410



E-TRARS-330



E-TRARS-410



E-VTRAS-200



E-VTRAS-180



E-VTRAS-200



E-ANA-410



E-ANA-330



E-ANA-410



E-ANA-500

Transgingival healing caps

The transgingival healing caps in Gr. 5 titanium can be identified via a laser-marking that reports the diameter, emergence profile and height. In case of transgingival healing screws with straight emergence profile, the marking only reports the platform diameter and height. The transgingival healing caps must be tightened at a maximum torque of 10 Ncm, using the HSM series of drivers, the full details and codes of which can be found on page 36-37.

The laser marking indicates the diameter (in the example 33=3.30mm) and the transgingival height (in the example 5=5mm).



The laser marking indicates the connection diameter (in the example 50=5.00mm), the maximum crown size (in the example 60 = 6.00 mm) and the transgingival height (in the example 2 = 2.00 mm).

The transgingival caps for implants \varnothing 3.30 and 4.10SP have a M1.8 thread (like the thread of the implant platform). The transgingival caps for implants 3.75, 4.10 and 5.00 have a M2.0 thread.



implant diameter

**ø 3.30 mm and
ø 4.10SP mm**

**ø 3.75 mm and
ø 4.10 mm**

ø 5.00 mm

Transgingival healing caps
Anatomical emergence profile
Transgingival H. 2 mm



E-TMG-330-372

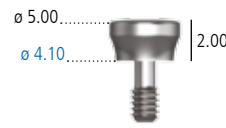

E-TMG-410-502



E-TMG-500-602

Transgingival healing caps
Anatomical emergence profile
Transgingival H. 3 mm



E-TMG-330-373



E-TMG-410-503

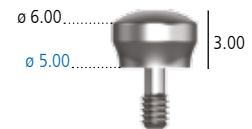

E-TMG-500-603

Transgingival healing caps
Anatomical emergence profile
Transgingival H. 5 mm

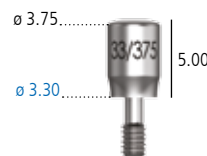

E-TMG-330-375

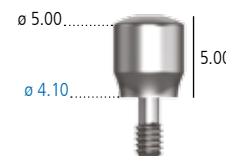

E-TMG-410-505



E-TMG-500-605

Transgingival healing caps
Straight emergence profile
Transgingival H. 2 mm



E-TMG-330-2

Transgingival healing caps
Straight emergence profile
Transgingival H. 3 mm



E-TMG-330-3

Transgingival healing caps
Straight emergence profile
Transgingival H. 5 mm



E-TMG-330-5

Impression and model phase

The components for the phase of taking the impression and creating the model are produced by the same maximum precision CNC machines that produce the respective implants; this ensures a real guarantee of precision from the point of view of tolerance and fidelity in the reproduction of the clinical situation. The open tray and closed tray transfers are made of Gr. 5 titanium, anodised according to the colour code of the reference implant platform.

Closed tray transfer: ideal for taking impressions with the closed tray technique, the repositioning face allows the transfer to be put back exactly in the impression material so as to reproduce the orientation of the connection precisely.

Open tray transfer: handy for use when there is a condition of parallelism between implants. The retentive design guarantees a steady grip in the upper portion of the impression.



Analog: anodised according to the colour code, like the transfers, to identify the different prosthetic platforms.



Open tray transfer

implant diameter

ø 3.30 mm and
ø 4.10SP mm

ø 3.75 mm and
ø 4.10 mm

ø 5.00 mm

Open tray transfer
Anatomical emergence
Connecting screw included

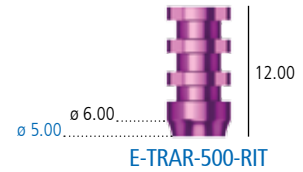
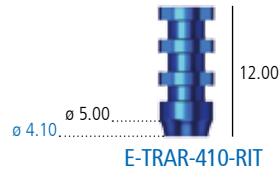
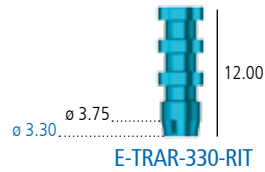

Open tray transfer
Straight emergence
Connecting screw included

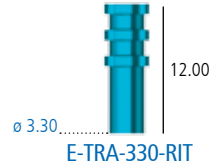

Connecting screw
Supplied with the transfers, it can
also be ordered separately as a spare

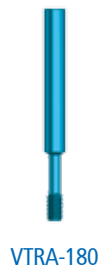

WARNING: In case of prostheses on more than one post, it is recommended to glue the open tray transfers together with resin in order to guarantee stability and solidity of the impression.

Closed tray transfer

implant diameter

ø 3.30 mm and
ø 4.10SP mm

ø 3.75 mm and
ø 4.10 mm

ø 5.00 mm

Closed tray transfer
Connecting screw included

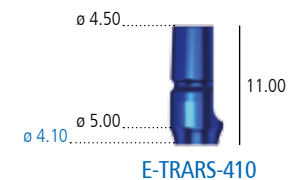
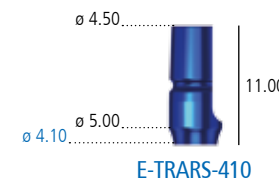
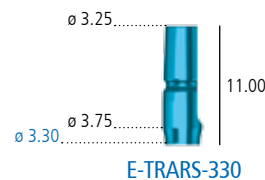

Connecting screw
Supplied with the transfers, it can
also be ordered separately as a spare

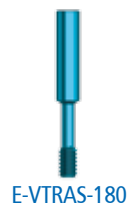

Analogues

implant diameter

ø 3.30 mm and
ø 4.10SP mm

ø 3.75 mm and
ø 4.10 mm

ø 5.00 mm

Analogue

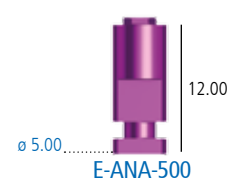
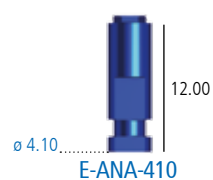
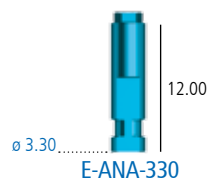

Recommended tightening torque: 8-10 Ncm.

All measurements are given in mm, unless indicated otherwise

SIMPLE temporary posts

The SIMPLE prosthetic protocol calls for practical and simple solutions to create the temporary posts. The temporary posts can be used in a conventional way after the bone healing period, or immediately after surgical insertion of the implants, if conditions exist for immediate loading. Instead of using transgingival healing screws, depending on the prosthetic protocols adopted, it is possible to condition the tissues with the temporary prosthesis made using these posts.

PEEK is an extremely resistant and highly biodegradable polymer, easy to drill even chair-side. The titanium base, with an anatomical emergence profile, guarantees maximum connection precision. These posts have a connection hexagon which allows them to be repositioned; they are therefore ideal as a support for cement-retained single crowns.



In Simple aesthetic posts, the wider flaring of the transgingival profile, adaptable to any anatomy by drilling, simplifies the immediate aesthetic conditioning of the mucosa.

These posts do not have the non-rotational and repositioning connection hexagon; they are therefore useful for making multiple temporary structures to be screwed directly onto the implants.



implant diameter

**ø 3.30 mm and
ø 4.10SP mm**

**ø 3.75 mm and
ø 4.10 mm**

ø 5.00 mm

SIMPLE temporary posts in PEEK
With Gr. 5 titanium base
Anatomical emergence profile
Repositionable
With hexagon
Connecting screw included

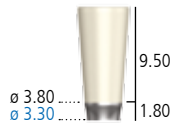

E-MPSR-330

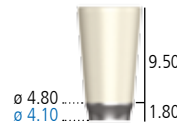

E-MPSR-410

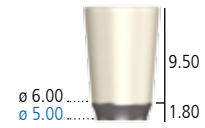

E-MPSR-500

SIMPLE temporary posts in titanium
Anatomical emergence profile
Repositionable
With hexagon
Connecting screw included

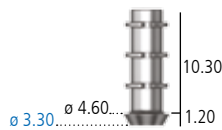

E-MPSA-330-EX

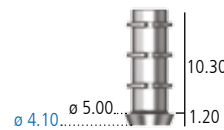

E-MPSA-410-EX

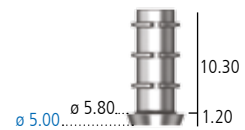

E-MPSA-500-EX

SIMPLE temporary posts in titanium
Anatomical emergence profile
Non-repositionable
Without hexagon, rotating
Connecting screw included

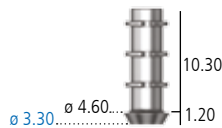

E-MPSA-330

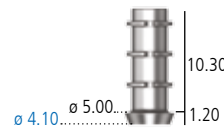

E-MPSA-410

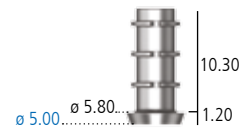

E-MPSA-500

SIMPLE aesthetic temporary posts
in titanium
Wide emergence profile
Non-repositionable
Without hexagon, rotating
Connecting screw included

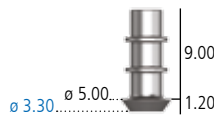

E-MPS-330

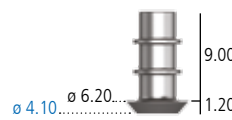

E-MPS-410

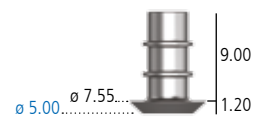

E-MPS-500

Connecting screw
Supplied with the temporary posts,
it can also be ordered separately as
a spare



VM-180
VM-180-10



VM-200
VM-200-10

Use
VM-200

Single pack
Pack of 10 pieces

WARNING: it is recommended always to use test screws for the laboratory phases and to keep the new screw supplied for the final fastening in the mouth.

Recommended tightening torque: 20-25 Ncm.

All measurements are given in mm, unless indicated otherwise.

Pre-made posts

Made of Gr. 5 titanium, these posts are subjected to a controlled passivation process that changes their surface colour: the result is a characteristic golden pale yellow colour. This colour is obtained through an anodising process and, therefore, there is no type of coating, which allows combining the advantages of a highly biocompatible surface with prosthetic reconstructions that are very aesthetically pleasing.

The golden colour makes them ideal for prosthetic rehabilitations of particular aesthetic importance.

Posts with passing screw angled at 15°.



The internal hexagon guarantees the non-rotational aspect and precise repositioning of the post.



implant diameter	ø 3.30 mm and ø 4.10SP mm	ø 3.75 mm and ø 4.10 mm	ø 5.00 mm
Pre-made straight posts Repositionable Anatomical emergence Transgingival H. 1 mm Connecting screw included	 ø 3.30... ø 3.75... E-MD-330-371	 ø 4.10... ø 5.00... E-MD-410-501	 ø 5.00... ø 6.00... E-MD-500-601
Pre-made straight posts Repositionable Anatomical emergence Transgingival H. 2 mm Connecting screw included	 ø 3.30... ø 3.75... E-MD-330-372	 ø 4.10... ø 5.00... E-MD-410-502	 ø 5.00... ø 6.00... E-MD-500-602
Pre-made straight posts Repositionable Anatomical emergence Transgingival H. 4 mm Connecting screw included	 ø 3.30... ø 3.75... E-MD-330-374	 ø 4.10... ø 5.00... E-MD-410-504	 ø 5.00... ø 6.00... E-MD-500-604
Pre-made straight posts Repositionable Straight emergence Transgingival H. 1 mm Connecting screw included	 ø 3.30... E-MD-330-1	-	-
Pre-made straight posts Repositionable Straight emergence Transgingival H. 2 mm Connecting screw included	 ø 3.30... E-MD-330-2	-	-
Pre-made straight posts Repositionable Straight emergence Transgingival H. 4 mm Connecting screw included	 ø 3.30... E-MD-330-4	-	-
Pre-made posts angled at 15° Repositionable Anatomical emergence Connecting screw included	 ø 3.30... ø 3.75... E-MAR15-330	 ø 4.10... ø 4.50... E-MAR15-410	 ø 5.00... ø 5.50... E-MAR15-500
Pre-made posts angled at 15° Repositionable Straight emergence Connecting screw included	 ø 3.30... E-MA15-330	-	-
Connecting screw supplied with the pre-made posts, it can also be ordered separately as a spare Single pack Pack of 10 pieces	 VM-180 VM-180-10	 VM-200 VM-200-10	Use VM-200

Recommended tightening torque: 20-25 Ncm.

All measurements are given in mm, unless indicated otherwise.

Standard and Simple millable posts

These posts are made of grade 5 titanium and are able to respond to complex anatomical requirements in terms of both narrow prosthetic spaces and disparallel implants. Alongside the traditional prosthetic protocols, Sweden & Martina has developed innovative solutions in collaboration with distinguished professionals and universities. Among these, the SIMPLE Technique allows perfect conditioning of the mucosa starting with temporary posts (see page 50) and uses a millable post with large dimensions for making a primarily custom-built final prosthesis

SIMPLE millable posts have a very wide emergence profile which can be adapted to any anatomy obtained with SIMPLE temporary aesthetic posts in the immediate conditioning phase.



Straight millable posts, with their characteristic profile in the shape of an inverted cone, are suitable for angles of up to 10° and for small profiles.

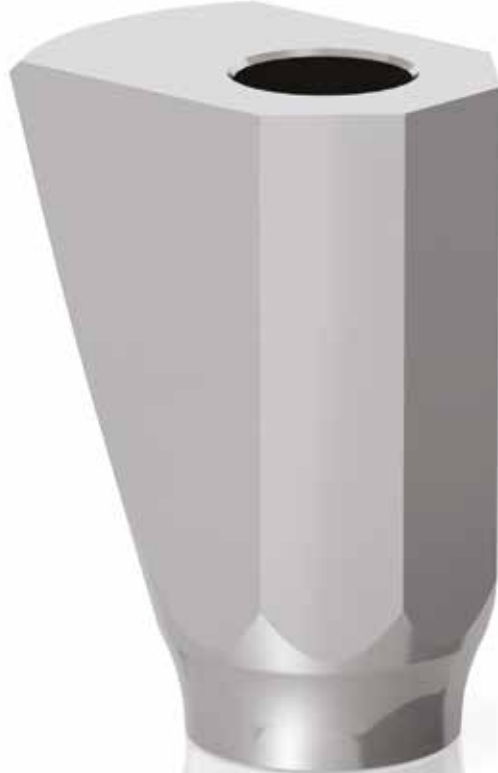

Pre-unloaded posts allow very pronounced angles to be reached, up to 25°, limiting the time needed to reduce them by milling.





implant diameter

**ø 3.30 mm and
ø 4.10SP mm**

**ø 3.75 mm and
ø 4.10 mm**

ø 5.00 mm

Straight millable posts
Repositionable
With hexagon
Connecting screw included

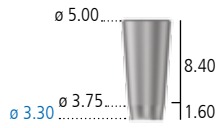

E-MFD-330-50

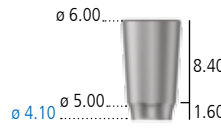

E-MFD-410-60

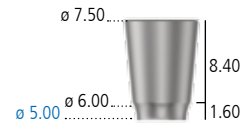

E-MFD-500-75

Pre-unloaded millable posts
Repositionable
With hexagon
Connecting screw included

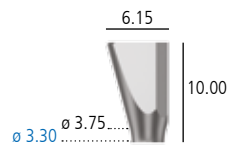

E-MFP-330-50

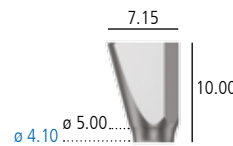

E-MFP-410-60

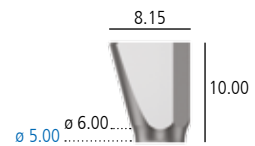

E-MFP-500-75

SIMPLE millable posts
Repositionable
With hexagon
Connecting screw included



E-MFS-330



E-MFS-410



E-MFS-500

Connecting screw
Supplied with the millable posts, it
can also be ordered separately as a
spare



**VM-180
VM-180-10**



**VM-200
VM-200-10**

Use
VM-200

Single pack
Pack of 10 pieces

WARNING: it is recommended always to use test screws for the laboratory phases and to keep the new screw supplied for the final fastening in the mouth.

Castable posts with alloy base

This solutions combines the simplicity of castable solutions with a gold alloy base that is highly biocompatible and highly resistant to corrosion. The melting point of the alloy is such as to preserve the base against dimensional alterations at the time of overcasting the castable part.



The non repositionable version presents an internal coupling cylinder which guarantees the simple insertion of multiple structures.

The repositionable version is suitable for creating single elements.

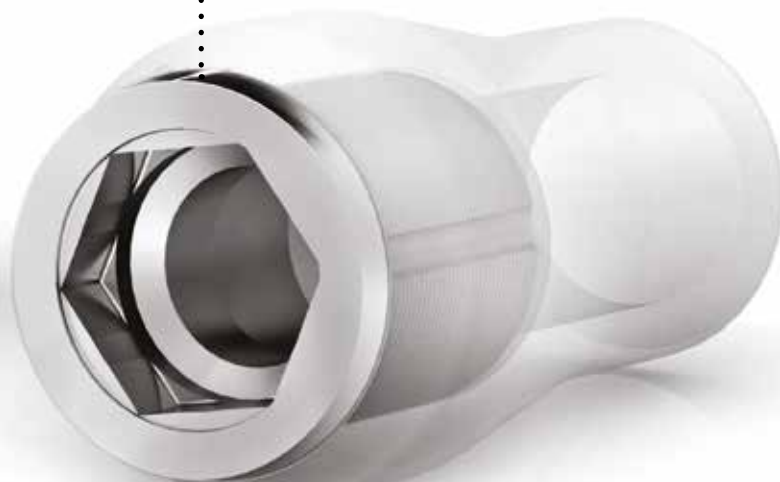

implant diameter
**ø 3.30 mm and
ø 4.10SP mm**
**ø 3.75 mm and
ø 4.10 mm**
ø 5.00 mm

Castable posts
With premade alloy base for
overcasting
Repositionable
With hexagon
Connecting screw included

E-UC-330-EX

E-UC-410-EX

E-UC-500-EX

Castable posts
With premade alloy base for
overcasting
Non-repositionable
Rotating
Connecting screw included

E-UC-330-ROT

E-UC-410-ROT

E-UC-500-ROT

Spare castable sleeves for castable
posts with alloy bases

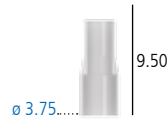
E-UCC-330

E-UCC-410

E-UCC-500

Connecting screw
Supplied with the millable posts, it
can also be ordered separately as a
spare

**VM-180
VM-180-10**

**VM-200
VM-200-10**

Use
VM-200

Single pack
Pack of 10 pieces

WARNING: it is recommended always to use test screws for the laboratory phases and to keep the new screw supplied for the final fastening in the mouth.

For the technical specifications of the gold alloy "1" refer to page 89.

Recommended tightening torque: 20-25 Ncm.

All measurements are given in mm, unless indicated otherwise.

Fully castable posts

Sweden & Martina fully castable posts are made of PMMA, a resin that does not leave any residue during the casting process; like all the prosthetic components, these posts are made by turning too, with consequent respect of micrometric tolerances.





implant diameter	ø 3.30 mm and ø 4.10SP mm	ø 3.75 mm and ø 4.10 mm	ø 5.00 mm
Fully castable posts Repositionable With hexagon Anatomical emergence Connecting screw included	 E-CCR-330-EX	 E-CCR-410-EX	 E-CCR-500-EX
Fully castable posts Repositionable With hexagon Straight emergence Connecting screw included	 E-CC-330-EX	-	-
Fully castable posts Non-repositionable Rotating Anatomical emergence Connecting screw included	 E-CCR-330-ROT	 E-CCR-410-ROT	 E-CCR-500-ROT
Fully castable posts Non-repositionable Rotating Straight emergence Connecting screw included	 E-CC-330-ROT	-	-
Connecting screw Supplied with the millable posts, it can also be ordered separately as a spare			Use VM-200
Single pack Pack of 10 pieces	VM-180 VM-180-10	VM-200 VM-200-10	

WARNING: it is recommended always to use test screws for the laboratory phases and to keep the new screw supplied for the final fastening in the mouth.

Prosthesis on intermediate abutments

These abutments are composed of a titanium base, which screws directly onto the implants, characterised by a small upper cone with a height of 0.70 mm, the same for all the connection diameters, which allows easy insertion and removal of the over-structures, even in case of slight disparallelism. Castable sleeves are supplied with the abutment, to be used for modelling and casting the over-structure, and the respective connecting screw. A small hexagon is found at the base of the cone which is used as a "key for screwing" the piece to the implant. To transfer the abutment into the oral cavity each package contains a practical plastic carrier (code AVV-ABUT-DG, not available separately). For the final fixing of the abutments to the implants, instead, use the special key, code AVV2-ABUT, not included in the surgical kits, but in the Screw-Kit of prosthetic drivers, and it can also be ordered separately (see table on page 37).

The torque recommended for fastening the direct screw-retained abutments is 25-30 Ncm.





implant diameter	ø 3.30 mm and ø 4.10SP mm	ø 3.75 mm and ø 4.10 mm	ø 5.00 mm
Standard Abutments Non-repositionable with straight screwing Complete with castable sleeve and respective connecting screw Emergence H. 2.5 mm	 E-ABUT-330-2.5	 E-ABUT-410-2.5	Use E-ABUT-410-2.5
Standard Abutments Non-repositionable with straight screwing Complete with castable sleeve and respective connecting screw Emergence H. 3.5 mm	 E-ABUT-330-3.5	 E-ABUT-410-3.5	Use E-ABUT-410-3.5
Protection cap for abutments	 E-ABUT-VT	Use E-ABUT-VT	Use E-ABUT-VT
Spare castable sleeve, for abutments	 E-ABUT-CC	Use E-ABUT-CC	Use E-ABUT-CC
Universal spare prosthetic screws for fastening the prosthesis to the abutments	 VABUT	Use VABUT	Use VABUT
Open tray transfer without hexagon, for abutments Connecting screw included	 E-TRABUT	Use E-TRABUT	Use E-TRABUT
Spare screws for open tray transfer of the abutments	 VTRABUT	Use VTRABUT	Use VTRABUT
Abutment analogs	 E-ANABUT	Use E-ANABUT	Use E-ANABUT

WARNING: it is recommended always to use test screws for the laboratory phases and to keep the new screw supplied for the final fastening in the mouth.

Recommended tightening torque for securing the prosthetic screws: 20-25 Ncm.

P.A.D. Disparallel Screwed Prosthesis

The P.A.D. systematics (Disparallel Screwed Prosthesis) was designed to facilitate the production of multiple screwed prostheses, even in the presence of very divergent implants and disparallel prosthetic emergences. The P.A.D. angled abutments, in particular, are the simplest and most reliable solution for implants positioned in distal saddles with high inclination. The P.A.D. prosthetic system is very versatile, starting from the wide range of straight abutments (available in various transgingival heights of 1.5, 3 and 4 mm), angled abutments (available with angles of 30° and 17° and transgingival heights of 3 and 5 mm), and a complete line of components necessary for producing the over-structures (transfers, analogues, sleeves, etc.).

P.A.D. posts: these all have the same upper cone, angled at 15°, which facilitates the manoeuvres of inserting and removing multiple screwed prostheses.

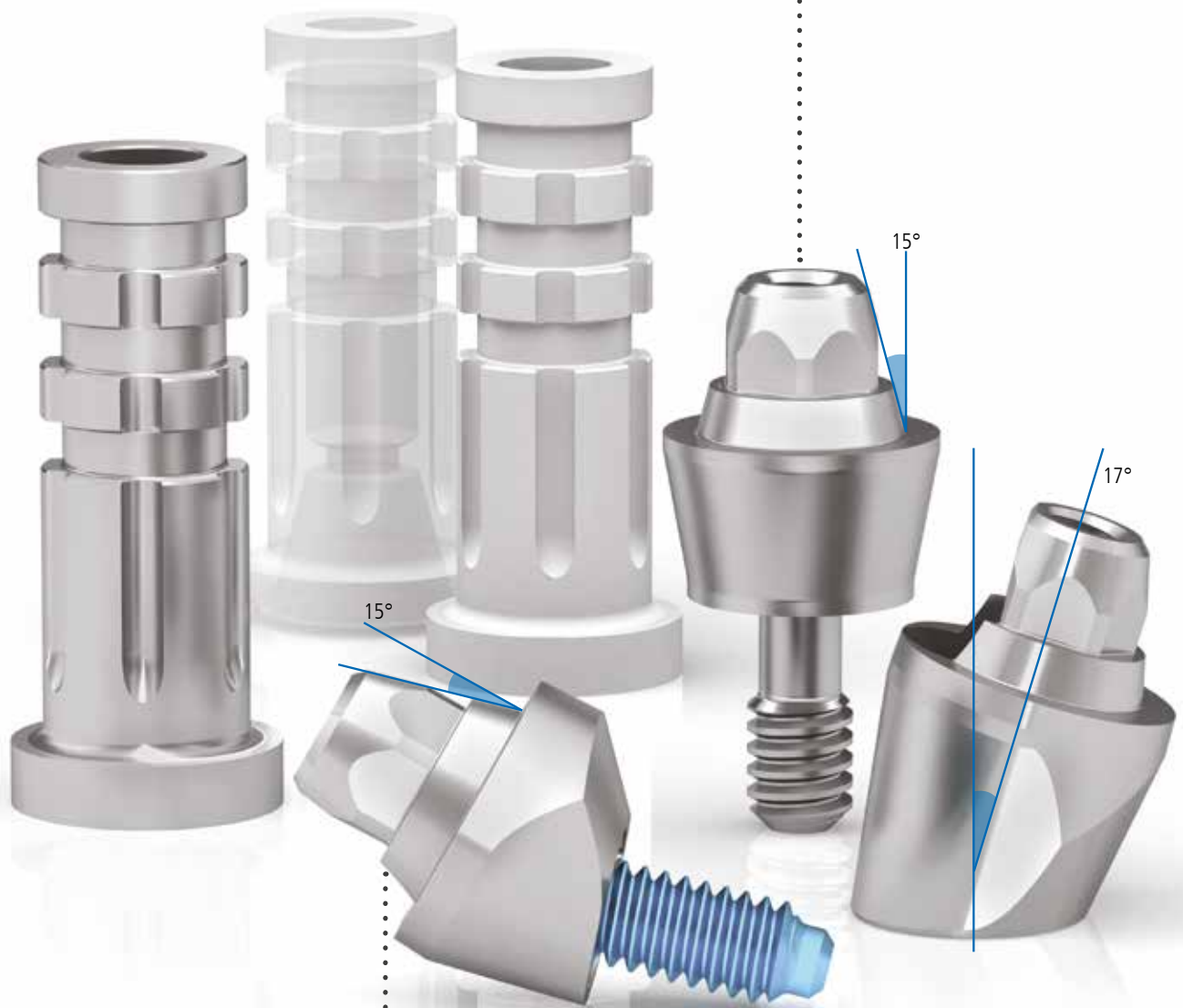

The upper cone allows further repositioning of the prosthetic structure by 15° on each side, which in the case of angled P.A.D. abutments are added to the angle of 17° or 30°. This characteristic allows easy management of disparallelism of up to 45° on each side.



implant diameter	ø 3.30 mm and ø 4.10SP mm	ø 3.75 mm and ø 4.10 mm	ø 5.00 mm
Straight P.A.D. abutments Direct screw-retained Transgingival H. 1.5 mm	 E-PAD-AD330-15	 E-PAD-AD410-15	Use E-PAD-AD410-15
Straight P.A.D. abutments Direct screw-retained Transgingival H. 3 mm	 E-PAD-AD330-30	 E-PAD-AD410-30	Use E-PAD-AD410-30
Straight P.A.D. abutments Direct screw-retained Transgingival H. 4 mm	-	 E-PAD-AD410-40	Use E-PAD-AD410-40
P.A.D. abutment angled at 17° Transgingival H. 3 mm Connecting screw included	 E-PAD-AA330-173	 E-PAD-AA410-173	Use E-PAD-AA410-173
P.A.D. abutment angled at 17° Transgingival H. 5 mm Connecting screw included	-	 E-PAD-AA410-175	Use E-PAD-AA410-175
P.A.D. abutment angled at 30° Transgingival H. 3 mm Connecting screw included	 E-PAD-AA330-303	 E-PAD-AA410-303	Use E-PAD-AA410-303
P.A.D. abutment angled at 30° Transgingival H. 5 mm Connecting screw included	-	 E-PAD-AA410-305	Use E-PAD-AA410-305
Spare screws for fastening the P.A.D. angled abutments to the implants Supplied with the P.A.D., they can also be ordered separately			Use PAD-VM-200
Single pack Pack of 10 pieces	PAD-VM-180 PAD-VM-180-10	PAD-VM-200 PAD-VM-200-10	









To transfer **straight** abutments into the oral cavity each package contains a practical plastic carrier (code AVV-ABUT-DG, not available separately). For fixing the abutments to the implants, instead, use the special driver, code AVV2-ABUT. The torque recommended for fastening the direct screw-retained abutments is 25-30 Ncm.

To transfer **angled** abutments into the oral cavity, a special instrument is available (code PAD-CAR-ABUA), present in the Screw Kit and which can be ordered separately (see page 37). To stabilise the abutment in the instrument a screw must be used (code PAD-VTRAL-140), to be ordered separately. The recommended tightening torque is 20-25 Ncm.

WARNING: it is recommended always to use test screws for the laboratory phases and to keep the new screw supplied for the final fastening in the mouth.

All measurements are given in mm, unless indicated otherwise.





PROSTHETIC COMPONENTS

code	description
 <p>PAD-CG</p>	<p>Protection cap for P.A.D. abutments in Gr. 5 titanium, to be used if the abutments are not immediately "provisionalised". Connecting screw included (code PAD-VP-140), available also as a spare, to be tightened at 8-10 Ncm</p>
 <p>PAD-CAP</p>	<p>Rotating caps in POM for direct impression taking on P.A.D. abutments</p>
 <p>PAD-CAP-EX</p>	<p>Non-rotating caps in POM for direct impression taking on P.A.D. abutments, with hexagon</p>
 <p>PAD-TRA</p>	<p>Open tray transfer in Gr. 5 titanium for P.A.D. abutments, rotating. Long transfer screw included (code PAD-VTRAL-140), suitable for open impression tray and available also as a spare</p>
 <p>PAD-TRA-EX</p>	<p>Open tray transfer in Gr. 5 titanium for P.A.D. abutments, with hexagon, non-rotating. Long transfer screw included (code PAD-VTRAL-140), suitable for open impression tray and available also as a spare</p>
 <p>PAD-VTRAL-140</p>	<p>Spare Spare screw for P.A.D. abutment transfer supplied with the transfers, it can be ordered separately as a spare</p>
 <p>PAD-ANA</p>	<p>Analog for P.A.D. abutment in Gr. 5 titanium. Long transfer screw included (code PAD-VTRAL-140), suitable for open impression tray and available also as a spare</p>
 <p>PAD-CC</p>	<p>Castable sleeves in PMMA for P.A.D. abutments, rotating. Connecting screw included (code PAD-VP-140), available also as a spare. Attention: The recommended tightening torque for all the over-structures obtained by casting to the abutments is 20-25 Ncm. However, before casting, care must be taken in the laboratory to ensure that the castable sleeves are not fastened to the models with a torque exceeding 8-10 Ncm, because polymers are not as resistant as metal</p>
 <p>PAD-CC-EX</p>	<p>Castable sleeves in PMMA for P.A.D. abutments, with hexagon, non-rotating. Connecting screw included (code PADVP- 140), available also as a spare. Attention: The recommended tightening torque for all the over-structures obtained by casting to the abutments is 20-25 Ncm. However, before casting, care must be taken in the laboratory to ensure that the castable sleeves are not fastened to the models with a torque exceeding 8-10 Ncm, because polymers are not as resistant as metal</p>

Recommended tightening torque for securing the prosthetic screws: 20-25 Ncm.

All measurements are given in mm, unless indicated otherwise.

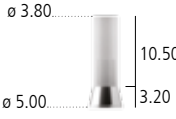



code	description
 PAD-CP	PEEK sleeves for P.A.D. abutments, rotating. They are specifically for creating a temporary prosthesis or in cases when it is necessary to reline an old prosthesis for using as a temporary one. Connecting screw included (code PAD-VP-140), available also as a spare, to be tightened at 20-25 Ncm
 PAD-CP-EX	PEEK sleeves for P.A.D. abutments, with hexagon, non-rotating. They are specifically for creating a temporary prosthesis or in cases when it is necessary to reline an old prosthesis for using as a temporary one. Connecting screw included (code PADVP- 140), available also as a spare, to be tightened at 20-25 Ncm
 PAD-UC	Castable posts in PMMA with a pre-made base in gold alloy type "1", rotating, not repositionable, for overcasting on P.A.D. abutments. Connecting screw included (code PAD-VP-140), available also as a spare, to be tightened at 20-25 Ncm regardless of the working phase, because the head of the screw never rests on the PMMA, but always on the alloy base. The castable sleeve is also available as a spare (code A-CCUCR-330)
 PAD-VP-140	Spare screw for P.A.D. abutment prosthetic components Also available in packs of 10 pieces (code PAD-VP-140-10)

For the technical specifications of the gold alloy "1" and of PMMA, refer to pages 89 and 87 respectively.

Recommended tightening torque for securing the prosthetic screws: 20-25 Ncm.

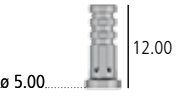
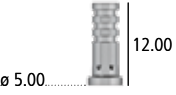
P.A.D. components for relining and gluing technique

code	description
 PAD-CT	Sleeves in Gr. 5 titanium for P.A.D. abutments, rotating. They are specifically for an immediate and final prosthetisation process or for relining an old prosthesis to be used as a temporary post. Connecting screw included (code PAD-VP-140), available also as a spare, to be tightened at 20-25 Ncm
 PAD-CT-EX	Sleeves in Gr. 5 titanium for P.A.D. abutments, with hexagon, non-rotating. They are specifically for an immediate and final prosthetisation process or for relining an old prosthesis to be used as a temporary post. Connecting screw included (code PAD-VP-140), available also as a spare, to be tightened at 25-30 Ncm
 PAD-CCEM	Castable posts in PMMA for cementing on titanium sleeves Effective for prosthetisation without residual tensions.

P.A.D. prostheses for "D.P.F." Technique (Direct Prosthetic Framework)

P.A.D. abutments have proven to be a valid support for creating various simplified prosthetic protocols, including the creation of temporary posts for full-arch implant rehabilitations with immediate loading with a very simple and safe procedure. The D.P.F. components have been specially developed for creating a castable resin structure directly in the oral cavity that is absolutely passive, not restricted by connection geometries and with the additional advantage of being made without errors due to the taking of the impression and the development of the model. The intra-oral cementing of the metal truss obtained subsequently by casting allows the times for inserting the reinforced temporary post to be reduced to 8 hours after the end of surgery, while still maintaining the important properties of resistance and passivity during the first phase of implant loading. The temporary post created in this way can also be used as a positioning stent for making the final prosthesis.

STEP 1

The castable bar is fixed to the caps with a photo-polymerisable resin.



STEP 3







The product is cast in the laboratory, obtaining the metal structure for making the finished truss.

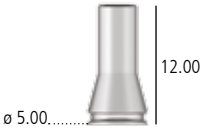

STEP 2

After photo-polymerisation of the truss, the product is removed from the oral cavity.



code	description
 <p data-bbox="256 555 325 584">PAD-LV</p>	<p data-bbox="483 439 1465 555">Complete pack of all the prosthetic components for the "D.P.F." technique on a single P.A.D. abutment. The pack includes the titanium sleeve (PAD-CT-LV), the castable centring device (PAD-CC-LV), the anti-escape plug (PAD-TR-LV), the protective o-ring (PAD-ORING-LV) and the connecting screw (PAD-VP-140) to be tightened at 20-25 Ncm, available also as a spare.</p>
 <p data-bbox="244 741 339 770">PAD-CT-LV</p>	<p data-bbox="759 656 1190 712">Spare titanium sleeve for the "D.P.F." technique. The pack does not include the connecting screw.</p>
 <p data-bbox="244 931 339 958">PAD-CC-LV</p>	<p data-bbox="719 857 1230 887">Spare castable centring device for the "D.P.F." technique.</p>
 <p data-bbox="244 1153 339 1180">PAD-TR-LV</p>	<p data-bbox="751 1064 1198 1093">Spare anti-escape plug for the "D.P.F." technique.</p>
 <p data-bbox="225 1370 357 1397">PAD-ORING-LV</p>	<p data-bbox="799 1279 1150 1308">Spare o-ring for the "D.P.F." technique.</p>
 <p data-bbox="236 1585 344 1612">PAD-VP-140</p>	<p data-bbox="715 1485 1238 1541">Spare screw for P.A.D. abutment prosthetic components Also available in packs of 10 pieces (code PAD-VP-140-10)</p>
 <p data-bbox="264 1805 320 1832">BARC</p>	<p data-bbox="834 1715 1118 1744">Castable bar, L. 5 cm, Ø 2.2 mm</p>

Individualised prosthesis Echo2

In case of an individualised prosthesis, maximum aesthetics and design flexibility are obtained with ECHO individual posts and with ECHO Direct Bridges, designed using the CAD-CAM technique and produced at the Sweden & Martina ECHO milling centre. The individual posts in titanium are an evolution of the standard millable posts and allow the prosthesis to adapt perfectly to the patient's gingival anatomy, which is difficult to obtain using traditional laboratory techniques. Posts completely made of zirconium oxide are also available, which are the most advanced individualised solution today since they present many advantages in terms of translucence of restoration, extreme customisation of the product, biocompatibility and absence of corrosion in the oral cavity, maximum connection precision, excellent resistance to occlusal loads, less invasiveness thanks to the perfect adaptation to the tissues and reduced session times.

All the individual components (posts, Direct Bridges, etc.) are sold complete with the necessary connecting screws. For zirconium components a washer is also supplied, made of a special high-resistance polymer to be placed between the head of the screw and its stop, with the function of absorbing and distributing forces between the parts. Screws and Peek washers are also available as spares.

The aluminium Scan-transfer is available for scanning (code E-CAMETRA330 and E-CAMETRA410, details on page 70).

Individual posts:

- titanium
- zirconium
- cobalt chrome



Screw-retained bar structures:

- milled cobalt chrome
- milled bio-titanium





Caps and bridges for prosthesis cemented on abutments:



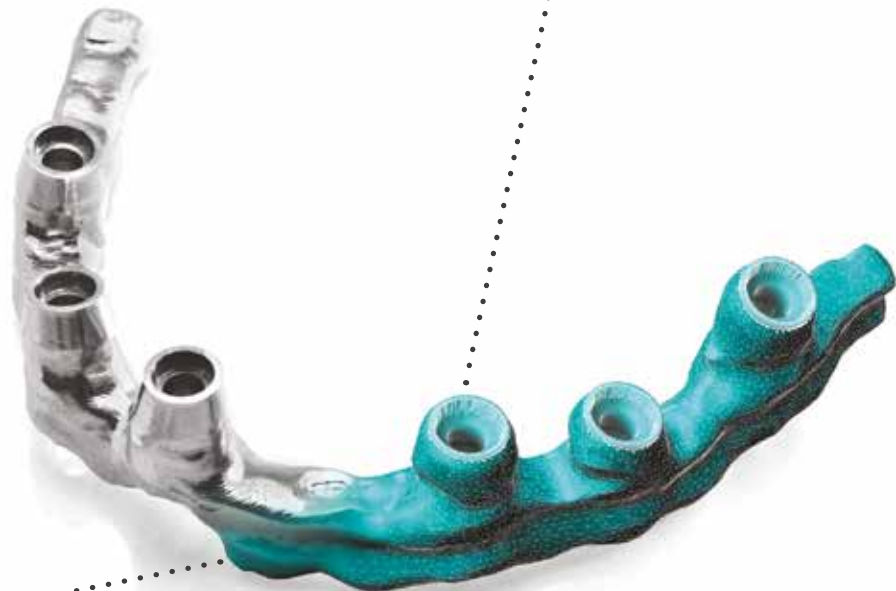





- zirconium
- milled cobalt chrome
- sintered cobalt chrome
- biomedical resin for temporary posts
- PMMA
- fibreglass
- milled bio-titanium



Screw-retained bridge structures and DIRECT BRIDGES

- zirconium
- milled cobalt chrome
- milled bio-titanium
- PMMA
- fibreglass

PROSTHETIC COMPONENTS

implant diameter	ø 3.30 mm and ø 4.10SP mm	ø 3.75 mm and ø 4.10 mm	ø 5.00 mm
ECHO Scan Transfer for implants (in aluminium ERGAL 7075) Connecting screw included	 E-CAMETRA330	 E-CAMETRA410	 Utilizzare E-CAMETRA410
Spare screws for ECHO Scan Transfer for implants	 VM-180 VM-180-10	 VM-200 VM-200-10	Use VM-200
Single pack Pack of 10 pieces			
Spare screws for fastening ECHO individual posts and prosthetic over- structures in zirconium oxide directly on implants (in Gr. 5 titanium, complete with lock ring washer)	-	 E-CAMTVABU200	-
Spare screws for fastening ECHO individual posts and prosthetic over- structures in titanium and cobalt chrome directly on implants	Use VM-180	Use VM-200	Use VM-200
Spare screws for fastening ECHO prosthetic over-structures in zirconium oxide directly on P.A.D. abutments (in Gr. 5 titanium, complete with lock ring washer)	 M1.4 PAD-VCAM-140	Use PAD-VCAM-140	Use PAD-VCAM-140
Spare screws for fastening ECHO prosthetic over-structures in titanium and cobalt chrome on P.A.D. abutments	 M1.4 PAD-VP-140	Use PAD-VP-140	Use PAD-VP-140
Spare lock ring washers for the head of the spare connecting screw, for ECHO individual posts in zirconium (in Classic Peek).		Use CAMPRON205-10	Use CAMPRON205-10
Pack of 10 pieces	CAMPRON205-10		

WARNING: In case of prostheses on more than one post, it is recommended to glue the transfers together with resin in order to guarantee stability and solidity of the impression.

Recommended tightening torque for securing the prosthetic screws: 20-25 Ncm.



T-Connect

T-Connect supports can be used for making individual prostheses in zirconium with open CAD-CAM systems, including Echo2 by Sweden & Martina, without sacrificing micrometric precision in the join between the platforms that can be obtained with traditional components. Users of Echo2 can also choose to use T-Connect supports: the zirconium posts obtained in this way require a small support base in titanium which avoids contact between the zirconium oxide body and the implant platform.

For further information on the compatible systems, contact the CAD-CAM product specialist at Sweden & Martina.



T-Connect: allow a perfect join to be obtained between prosthesis and implant with zirconium structures milled and sintered in the laboratory.



implant diameter

ø 3.30 mm and
ø 4.10SP mm

ø 3.75 mm and
ø 4.10 mm

ø 5.00 mm

T-Connect in Gr. 5 titanium for individualised posts in zirconium
Connecting screw included



E-BASTZR-S-330



E-BASTZR-S-410



E-BASTZR-S-500

Connecting screw supplied with the T-Connect, it can also be ordered separately as a spare



VM-180
VM-180-10



VM-200
VM-200-10

Use VM-200

Single pack
Pack of 10 pieces

WARNING: it is recommended always to use test screws for the laboratory phases and to keep the new screw supplied for the final fastening in the mouth..

Recommended tightening torque for securing the prosthetic screws: 20-25 Ncm.

Locator abutment

Locator abutments are a patented and versatile prosthetic solution for attaching overdentures to dental implants easily and safely. The Locator system allows easily correcting misalignment of divergent implants by up to 40° (20° for each implant) in limited occlusal spaces; given the limited amount of space occupied, Locator abutments are perfect for patients with a removable prosthesis.







These abutments are made of Gr. 5 titanium and are available in different transgingival heights. The Locators are tightened at a torque of 25-30 Ncm using the special driver to be ordered separately (code 8926-SW, short, and code 8927-SW, long).





Retainers with different flexibilities are available for easily inserting into the steel cap with the use of a practical instrument for retainer insertion. The different retentive capacities are easily identified based on a colour code. The blue, pink and transparent retainers can be used on implants with angles of up to 10°; orange, red and green retainers are used on implants with an angle between 10° and 20°.

PROSTHETIC COMPONENTS





implant diameter	ø 3.30 mm and ø 4.10SP mm	ø 3.75 mm and ø 4.10 mm	ø 5.00 mm
Locator abutment* Transgingival H. 1 mm	 1773	 1741	Use 1741
Locator abutment* Transgingival H. 2 mm	 1774	 1742	Use 1742
Locator abutment* Transgingival H. 3 mm	 1775	 1743	Use 1743
Locator abutment* Transgingival H. 4 mm	-	 1744	Use 1744

* *Locator abutments are medical devices manufactured and patented by Zest Anchors, Inc., 2061 Wineridge Place, Escondido, CA 92029, USA. Locator is a registered trademark of Zest Anchors, Inc. The European Agent for the purposes of MDD 93/42/EEC is Ventura Implant and Attachment Systems, 69 The Avenue, Ealing, London W13 8JR, England.*

Impression taking











code	description
 8530	Pack of 4 aluminium analogues for Locator abutments, one size for all platforms



code	description
	Pack of 4 aluminium transfers for Locator abutments, one size for all platforms, and 4 black polyethylene retainers (LDPE 993I) with low retention included (code 8515). The retainers are also available as spares
8505	
	Pack of 4 black polyethylene retainers (LDPE 993I) with low retention capacity for impression taking
8515	
	Pack of 4 black nylon parallelism pins (LDPE 993I) for Locator abutments
8517	
	Steel plate AISI 316L for measuring angles
9530	





PROSTHETIC COMPONENTS

Plastic caps and retainers for Locator abutments*

code	description
 8519-2	Kit containing 2 Gr. 5 titanium caps, 2 spacer rings in silicon rubber, 2 black polyethylene retainers (LDPE 993I) with low retention capacity for impression taking and 2 nylon retainers for each of the 4 different retention capacities, designed for slight disparallelism (up to 10°)
 8540-2	Kit containing 2 Gr. 5 titanium caps, 2 spacer rings in silicon rubber, 2 black polyethylene retainers (LDPE 993I) with low retention capacity for impression taking and 2 nylon retainers for each of the 4 different retention capacities, designed for severe disparallelism (between 10° and 20°)
 8550-2	Kit containing 2 steel caps, 2 spacer rings in silicon rubber, 2 black polyethylene retainers (LDPE 993I) with low retention capacity for impression taking and 2 nylon retainers for each of the 4 different retention capacities, designed for slight disparallelism (up to 10°)
 8514	Pack of 20 spacer rings in silicon rubber, for the prosthesis relining phase
 8515	Pack of 4 black polyethylene retainers (LDPE 993I) with low retention capacity for impression taking
 8524	Pack of 4 transparent nylon retainers, retention 5 lb corresponding to 2268 g for slight disparallelism (up to 10°)
 8527	Pack of 4 pink nylon retainers, retention 3 lb corresponding to 1361 g for slight disparallelism (up to 10°)
 8529	Pack of 4 blue nylon retainers, retention 1.5 lb corresponding to 680 g for slight disparallelism (up to 10°)
 8547	Pack of 4 green nylon retainers, retention 4 lb corresponding to 1814 g for severe disparallelism between 10° and 20°)
 8548	Pack of 4 red nylon retainers, retention 1 lb corresponding to 450 g for severe disparallelism between 10° and 20°)
 8915	Pack of 4 orange nylon retainers, retention 2 lb corresponding to 907 g for severe disparallelism between 10° and 20°)

* *Locator Abutments are medical devices manufactured and patented by Zest Anchors, Inc., 2061 Wineridge Place, Escondido, CA 92029, USA. Locator is a registered trademark of Zest Anchors, Inc. The European Agent for the purposes of MDD 93/42/EEC is Ventura Implant and Attachment Systems, 69 The Avenue, Ealing, London W13 8JR, England.*



code	description
	<p>Locator Core Tool. Steel instrument composed of:</p> <ul style="list-style-type: none"> - handle - driver (8390) for screwing Locator abutments. - push-rod (8397) for inserting retainers into the caps - spare (8394) for Locator Core Tool retainer
8393	
	<p>Steel push rod for inserting the retainers in the caps. Not necessary for those who already own or order the complete Locator Core Tool separately</p>
8397	
	<p>Steel driver for abutment screwing/unscrewing. Not necessary for those who already own or order the Locator Core Tool separately</p>
8390	
	<p>Retention jacket for the driver (8390) for transferring the Locator abutments into the oral cavity</p>
8394	

Overdentures anchored with ball attachments

These attachments have a small hexagon at the base of the ball for engaging the driver (N.B.: the driver code BASCC-EX is not included in the surgical kit, it is in the Screw Kit and may be ordered separately). This driver is compatible with the system's dynamometric ratchet.





implant diameter	ø 3.30 mm and ø 4.10SP mm	ø 3.75 mm and ø 4.10 mm	ø 5.00 mm
Ball attachment Transgingival H. 1 mm	 E-AS-330-1	 E-AS-410-1	Use E-AS-410-1
Ball attachment Transgingival H. 2 mm	 E-AS-330-2	 E-AS-410-2	Use E-AS-410-2
Ball attachment Transgingival H. 4 mm	 E-AS-330-4	 E-AS-410-4	Use E-AS-410-4
Analog of the ball attachment	 ANAS	Use ANAS	Use ANAS

code

description



BASCC-EX



Steel driver for ball attachments, with connector for dynamometric ratchet or digital connector.
(Not included in the surgical kit, included in the Screw Kit and can be ordered separately.)

Recommended tightening torque: 25-30 Ncm.





PROSTHETIC COMPONENTS

Accessories for overdentures on ball attachments

Polyamide caps for ball attachments

code	description
 CAP-TFL-1	Polyamide cap for ball attachments Ø 2.20 mm
 CONT-CAP-TFL-1	Steel container for polyamide cap with outer Ø 4.80 mm. The total height is 3.20 mm

Titanium caps for ball attachments





code	description
 CAP-TIT-1	Gr. 5 titanium cap complete with cap in two parts, titanium retention spring, and plastic mounting ring for ball attachments Ø 2.20 mm. The total height is 3.20 mm
 AN-CAP-TIT-1	Spare plastic ring for titanium cap height 2.20 mm
 MOL1-CAP-TIT-1	Spare retention spring for titanium caps, average hardness, steel, Ø 3.20 mm
 MOL2-CAP-TIT-1	Spare retention spring for titanium cap, soft, for progressive adaptation of the prosthesis, steel, Ø 3.20 mm
 AVV-CAP-TIT-1	Instrument for assembling and maintaining the titanium CAP-TIT-1

Caps in gold alloy for ball attachments

code	description
 CAP-1	Cap in gold alloy, complete with plastic positioning ring for ball attachments Ø 2.20 mm. The total height is 3.00 mm, and the outside diameter is 3.50 mm



O-ring retention devices for ball attachments

code	description
 99-440044*	Metal container in the shape of a ring for rubber O-rings. For ball attachments Ø 2.20 mm. The total height is 1.50 mm, and the outside diameter is 4.50 mm. Pack of 6 pieces
 99-443034*	Red ring in silicon for laboratory use, outside Ø 4.50 mm, height 1.50 mm. Pack of 12 pieces
 99-443035*	White ring in natural rubber, soft, outside Ø 4.50 mm, height 1.50 mm. Pack of 12 pieces
 99-443036*	Black ring in natural rubber, hard, outside Ø 4.50 mm, height 1.50 mm. Pack of 12 pieces

* The retention O-ring for ball attachments are manufactured by Implant Direct Sybron International, 27030 Malibù Hills Road, Calabasas Hills, 91301 U.S.A. The European Agent for the purposes of MDD 93/42/EEC is Kerr Italia S.r.l., via Passanti 332, 84018 Scafati (SA) Italy.

Overdentures on bars

code	description
 BARC-CAV-TIT	Castable bar, length 5.00 cm, height 3.00 mm, thickness 2.20 mm Ovoid-shaped profile with spacer
 CAV-TIT	Divisible bar attachment in titanium for oval bars height 3.00 mm, thickness 2.20 mm
 BARC	Castable bar, length 5.00 cm, Ø 2.20 mm
 CAV-375	Bar attachment in gold alloy, for round bars with Ø 2.20 mm

SFI-Bar

The total removable prosthesis supported by implants is acquiring more and more importance in prosthetic restorations. To enable patients to enjoy a substantially better quality of life on a long-term basis thanks to optimum retention, the principle of treatment with bars on implants has been radically reviewed, creating the SFI-Bar. The result is an exclusive solution that offers numerous clinical and economic advantages for patients, dentists and dental technicians in comparison with conventional bars.

The abutment driver for the SFI-Bar can be ordered separately, with code 07000046-SW. This driver is compatible with the system's dynamometric ratchet.

See pages 84-85 for the list of accessories available.

Chair-side and lab-side processing: Thanks to the extremely reduced production times, the SFI-Bar can be processed either chair-side or in the laboratory. In both cases the exclusive bar system with prefabricated elements is convincing for its almost universal possibilities of use, with costs reduced to a minimum in comparison with the traditional bar solution.

The bar prostheses made with the SFI-Bar can be supported by 3, 4, 5 or 6 implants, they take up less space in the mouth and present characteristics of biocompatibility. In case of repair it is possible to replace the individual elements without any problems.

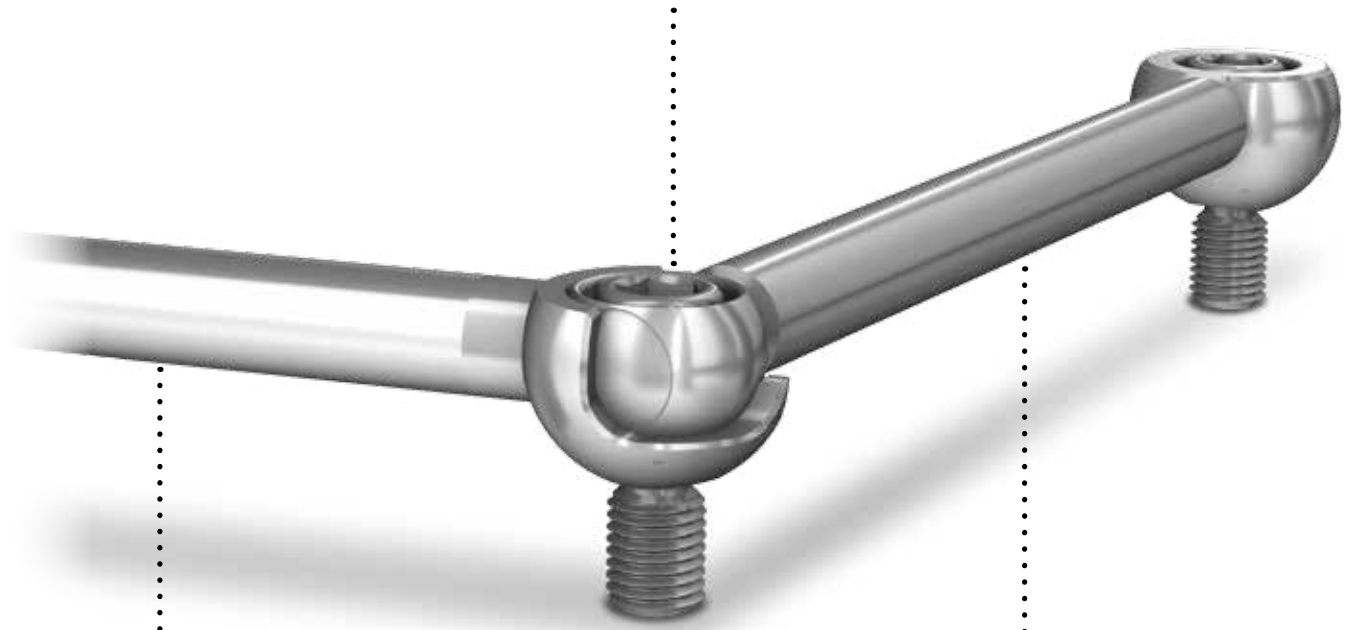

Immediate loading: SFI-Bar offers the ideal basis for carrying out the immediate loading treatment, which exploits the complete absence of stress that can be obtained with this prosthetic protocol. This improves acceptance of the prosthesis by the patient and creates the conditions for optimum osseointegration.















Passive Fit: The stress-free position of a bar treatment is a fundamental requirement for the long-term clinical success of a prosthesis supported by implants. SFI-Bar offers the ideal basis for carrying out the immediate loading treatment, which exploits the complete absence of stress that can be obtained with this prosthetic protocol.



implant diameter	ø 3.30 mm and ø 4.10SP mm	ø 3.75 mm and ø 4.10 mm	Ø 5.00 mm
Abutment for SFI-Bar Transgingival H. 4 mm	-		-
		05001182	
Abutment for SFI-Bar Transgingival H. 5 mm	-		-
		05001183	
Abutment for SFI-Bar Transgingival H. 6 mm	-		-
		05001184	

Recommended tightening torque: 25-30 Ncm.





OVERDENTURES

code	description	material	pack
 05000337	Prosthetization kit on 2 implants, including: 2 large ball connectors, 2 connecting screws, 1 tubular bar	Gr. 5 titanium	
 05000338	Prosthetization kit on 4 implants, including: 2 large ball connectors, 2 small ball connectors, 2 hemispherical shells, 4 connecting screws, 3 tubular bars	Gr. 5 titanium	
 05000668	Additional prosthetization kit, including: 1 large ball connector, 1 connecting screw, 2 tubular bars	Gr. 5 titanium	
 05000382	Tubular bar L. 20 mm	Gr. 5 titanium	
 05000383	Large ball connector	Gr. 5 titanium	
 05000384	Small ball connector	Gr. 5 titanium	
 05000385	Hemispherical shell	Gr. 5 titanium	
 05000386	Connecting screw	Gr. 5 titanium	
 05000344	Asymmetrical female L. 50 mm	gold alloy "2"	1 piece
 05000358	Female complete with sheaths L. 47.5 mm	grade 5 titanium and plastic material	1 bar with 12 segments, 6 yellow sheaths 6 red sheaths
 05000387	Female L. 47.5 mm	Gr. 5 titanium	1 bar with 12 segments
 05000388	Yellow retentive sheath – low retention	plastic material	6 pieces
 05000389	Red retentive sheath – medium retention	plastic material	6 pieces
 05000390	Green retentive sheath – high retention	plastic material	6 pieces

Instruments

code	description
	Instruments kit
07000108	
052082	Brass wire for resilience To be inserted between the bar and the female during polymerisation to ensure a vertical translation of the prosthesis
07000107	Transfer axis L. 26 mm
07000106	Tube guide
07000100	Guide for cutting tubular bars
07000114	Flathead screwdriver for screwing the abutments onto the implants
07000115	Allen screwdriver for screwing the connecting screws onto the abutments
070221	Thomas key
07000036	Positioning pin for sheaths
070198	Set of activators for Elitor females
070201	Macro deactivator for Elitor females
070347	Forceps
07000111	Implant planner
08000101	Discs for cutting tubular bars

Sweden & Martina auxiliary instruments

code	description
	Steel driver for abutments for SFI-Bar compatible with the dynamometric ratchet
07000046-SW	
	Mandrel for cutting discs, HP attachment
305/050HP	
	Abrasive corundum tip, HP attachment
733MARRHP	
	Rubber polishing head, HP attachment
9503HP	
	Rubber polishing head, CA attachment
9503CA	

MATERIAL COMPOSITION

GRADE 4 TITANIUM (cold worked)*

	Element	Maximum allowed values (%)	Tolerance
Chemical composition:	Nitrogen	0.05	+/- 0.02
	Carbon	0.08	+/- 0.02
	Hydrogen	0.015	+/- 0.002
	Iron	0.50	+/- 0.01 (%<0.25) +/- 0.15 (%>0.25)
	Oxygen	0.40	+/- 0.02 (%<0.20) +/- 0.03 (%>0.20)
	Titanium	remainder	-

Mechanical properties*

	Minimum allowed values
Tensile stress:	680 MPa (N/mm ²)
Yield strength (0.2%):	520 MPa (N/mm ²)
Elongation at yield:	15 %
Section reduction:	25 %

* This technical information complies with the express specifications of the regulations in force for the use of grade 4 titanium in implantology:

- ASTM F67-06: Standard Specification for unalloyed titanium, for surgical implant applications.
- ISO 5832-2:1999: Implant for surgery – Metallic materials – Part 2: Unalloyed titanium.

Please note: the use of bars obtained from cold processing, for the production of Sweden & Martina Spa implants, allows the exploitation of the mechanical characteristics of tensile strength and yield strength about 15% higher than those that can be obtained with a hot process (respectively 550 MPa and 483 MPa).

GRADE 5 TITANIUM

	Element	Maximum allowed values (%)	Tolerance
Chemical composition:	Nitrogen	0.05	+/- 0.02
	Carbon	0.08	+/- 0.02
	Hydrogen	0.012	+/- 0.002
	Iron	0.25	+/- 0.10
	Oxygen	0.13	+/- 0.02
	Aluminium	0.50÷6.50	+/- 0.40
	Vanadium	3.50÷4.50	+/- 0.15
	Titanium	remainder	-

Mechanical properties*

	Minimum allowed values
Tensile stress (for bar diameters up to 44.45 mm):	860 MPa (N/mm ²)
Yield strength (0.2%):	795 MPa (N/mm ²)
Elongation at yield:	10 %
Section reduction:	25 %

* This technical information complies with the express specifications of the regulations in force for the use of grade 5 titanium in implantology:

- ASTM F136-11: Standard Specification for wrought Titanium-6Aluminum-4Vanadium ELI (Extra low Interstitial) Alloy for surgical implant applications;
- ISO 5832-3:1996: Implants for surgery – Metallic materials – Part 3: Wrought titanium 6-aluminium 4-vanadium alloy.



PMMA

Chemical designation:	Polymethylmethacrylate
Colour:	Transparent
Physical and mechanical properties	
Density (DIN 53479)	1.18 g/cm ³
Yield strength (DIN 53454)	110 N/mm ²
Elongation at yield (DIN 53455)	5.5 %
Modulus of elasticity (DIN 53457)	115 N/mm ²
Tangential elastic modulus at 10 Hz (DIN 53445)	3300 N/mm ²
BRINELL hardness ball falling h961/30 (DIN 53456)	1700 N/mm ²
BRINELL hardness if the ball falls (DIN 53456)	200 N/mm ²
Thermal properties	
Coefficient of linear extension for 0...50C (DIN VDE 0304/01)	70·10 ⁻⁶ · 1/°C
Thermal conductivity (DIN 52612)	0.19 W/m °C
Oven temperature	≈ 160 °C
Regaining temperature	>80 °C
Maximum service temperature long term	78 °C
VICAT temperature, proceeding B (DIN 53460)	115 °C
ISO 75 flection resistance 1.80N/mm ² (DIN 53461)	105 °C
Heat resistance according martens (DIN 53458)	95 °C
Chemical properties	
Water absorption in weight increase after 1 day immersion (DIN 53495)	0.3 %

POM

Chemical designation	Polyoxymethylene (copolymer)
Colour	Natural opaque
Physical and mechanical properties	
Density (DIN 53479):	1.41 g/cm ³
Tensile strength (DIN EN ISO 527-2)	67 Mpa
Tensile strenght at yield (DIN EN ISO 527-2)	67 Mpa
Elongation at yield (DIN EN ISO 527-2):	9%
Elongation at break (DIN EN ISO 527-2):	32 %
Modulus of elasticity (flexural test) (DIN EN ISO 178):	2800 Mpa
Modulus of elasticity (tensile test) (DIN EN ISO 527-2):	2800 MPa
Ball indentation hardness (ISO 2039-1):	165 MPa
Impact strength (Charpy) (DIN EN ISO 179-1eU):	Not broken
Compression modulus (EN ISO 604):	2300 Mpa
Thermal properties	
Melting temperature (DIN 53765):	166 °C
Glass transition temperature (DIN 53765):	-60 °C
Service temperature short term:	140 °C
Service temperature long term:	100 °C
Specific heat (ISO 22007-4):	1.4 J/(gK)
Thermal conductivity (ISO 22007-4):	0.39 W/ (mK)
Thermal expansion (CLTE) 23-60°C (DIN EN ISO 11359-1;2):	13·10 ⁻⁵ /K
Thermal expansion (CLTE) 23-100°C (DIN EN ISO 11359-1;2):	14·10 ⁻⁵ /K
Chemical properties	
Water absorption 24h / 96h (23°C) (DIN EN ISO 62)	0.05/0.1%

COMPOSIZIONE DEI MATERIALI

PEEK *(tested on the same quantity of material)	Radiopaque	Classic
Chemical designation	Polyetheretherketone	Polyetheretherketone
Colour	Cream white opaque	Cream white opaque
Physical and mechanical properties		
Density:	1.65 g/cm ³	1,4 g/cm ³
Modulus of elasticity (tensile test) (DIN EN ISO 527-2):	5200 MPa	4100 MPa
Tensile strength (DIN EN ISO 527-2):	77 MPa	97 MPa
Tensile strength at yield (DIN EN ISO 527-2):	77 MPa	97 MPa
Elongation at yield (DIN EN ISO 527-2):	2%	5%
Elongation at break (DIN EN ISO 527-2):	2%	13%
Flexural strength (DIN EN ISO 178):	178 MPa	174 MPa
Modulus of elasticity (flexural test) (DIN EN ISO 178):	5000 MPa	4000 MPa
Compression modulus (EN ISO 604):	4000 MPa	3500 MPa
Thermal properties		
Glass transition temperature (DIN 53765):	-	150 °C
Service temperature short term:	300 °C	300 °C
Service temperature long term:	260 °C	260 °C
Chemical properties		
Water absorption 24h / 96h (23°C) (DIN EN ISO 62):	-	0.02/0.03 %



GOLD ALLOY	Gold alloy 1	Gold alloy 2	Gold alloy 3
Chemical designation	Gold alloy 1	Gold alloy 2	Gold alloy 3
Colour	White	Yellow	Yellow
Composition			
Au	60 %	> 68.60 %	70 %
Pt	24 %	2.45 %	8.5 %
Pd	15 %	3.95 %	-
Ir	1 %	0.05 %	0.10 %
Ag	-	11.85 %	13.40 %
Cu	-	10.60 %	7.50 %
Zn	-	2.50 %	0.50 %
Au + Pt Group Metals	-	75.35 %	-
Ru	-	-	-
Physical and mechanical properties			
Density:	18.1 g/cm ³	15.0 g/cm ³	15.7 g/cm ³
Melting range:	1400 ÷ 1460 °C	880 ÷ 940 °C	895 ÷ 1010 °C
Modulus of elasticity (tensile test):	115 GPa	97 GPa	100 GPa
Vickers Hardness HV1 (Gold alloy 1) HV5 (Gold alloy 2, Gold alloy 3)	160 (annealed) 250 (hardened) 220 (after deformation) 240 (after casting)	> 240	170 (annealed) 295 (hardened) 280 (selfhardening)
Proof stress Rp0.2	400 MPa (annealed) 700 (after deformation) 800 (after casting)	> 710 MPa (cold worked) 410 Mpa (soft) 680 Mpa (hardened)	380 MPa (annealed) 730 (after deformation)
Yield strenght Rm	600 Mpa (annealed) 850 (hardened) 850 (after deformation)	>790 MPa (cold worked) 535 MPa (soft) 780 MPa (hardened)	-
Elongation in %	20 % (annealed) 15 (hardened) 1 (after deformation)	> 4 % (cold worked) 35% (soft) 12% (hardened)	-

BIBLIOGRAPHY ON SWEDEN & MARTINA IMPLANTS

- Segura Andrés G., Martínez Lage J. F., Ferreira A., Faus López J., Agustín Panadero R.; Rehabilitación protésica en un maxilar atrófico a consecuencia de un trauma facial; *Gaceta Dental*, 2013; 244:112-118
- Canullo L., Micarelli C., Clementini M.; Hard tissue response to argon plasma cleaning treatment on titanium abutments: 2-year follow-up RCT; *European Journal of Oral Implantology*, 6 (Suppl. Spring), 2013; 521-522
- Rossi F., Lang N. P., De Santis E., Morelli F., Favero G., Botticelli D.; Bone-healing pattern at the surface of titanium implants: an experimental study in the dog; *Clinical Oral Implant Research*, Early View, First Published online on 2013, January 4th; DOI: 10.1111/cir.12019
- Canullo L., Micarelli C., Clementini M.; Fibroblast growth on titanium disks treated by argon plasma: an in vitro triple-blinded study; *European Journal of Oral Implantology*, 6 (Suppl. Spring), 2013; 529-530
- Canullo L., Micarelli C., Iannello G.; Microscopical and chemical surface characterization of the gingival portion and connection of an internal hexagon abutment before and after different technical stages of preparation; *Clinical Oral Implant Research*, 2013; 24: 606-611; DOI: 10.1111/j.1600-0501.2012.02499.x
- Canullo L., Heinemann F., Gedrange T., Biffar R., Kunert-Keil C.; Histological evaluation at different times after augmentation of extraction sites grafted with a magnesium-enriched hydroxyapatite: double-blinded randomized controlled trial; *Clinical Oral Implant Research*, Early View, First Published online on 2013, January 4th; DOI: 10.1111/cir.12035
- Canullo L., Micarelli C., Clementini M., Carinci F.; Cleaning procedures on customized abutments: microscopical, microbiological and chemical analysis; *Clinical Oral Implant Research*, 2012; 23 Suppl 7: 55-56; DOI: 10.1111/cir.12019
- Canullo L., Micarelli C., Lembo-Fazio L., Iannello G., Clementini M.; Microscopical and microbiological characterization of customized titanium abutments after different cleaning procedures; *Clinical Oral Implant Research*, Early View, First Published online on 2012, December 5th; DOI: 10.1111/cir.12089
- Wennstrom J. L., Derks J.; Is there a need for keratinized mucosa around implants to maintain health and tissue stability?; *Clinical Oral Implant Research*, 2012; 23 Suppl 6: 136-146; DOI: 10.1111/j.1600-0501.2012.02544.x
- Sisti A., Canullo L., Mottola M. P., Covani U., Barone A., Botticelli D.; Clinical evaluation of a ridge augmentation procedure for the severely resorbed alveolar socket: multicenter randomized controlled trial, preliminary results; *Clinical Oral Implant Research*, 2012; 23: 526-535; DOI: 10.1111/j.1600-0501.2011.02386.x
- Sailer I., Muhlemann S., Zwahlen M., Hammerle C. H. F., Schneider D.; Cemented and screw-retained implant reconstructions: a systematic review of the survival and complication rates; *Clinical Oral Implant Research*, 2012; 23 Suppl 6: 162-201; DOI: 10.1111/j.1600-0501.2012.02538.x
- Barone A., Orlando B., Cingano L., Marconcini S., Derchi G., Covani U.; A randomized clinical trial to evaluate and compare implants placed in augmented vs. non-augmented extraction sockets A 3-year evaluation; *Journal of Periodontology*, 2012; 83: 836-846; DOI: 10.1902/jop.2011.110205
- Sisti A., Canullo L., Mottola M. P., Iannello G.; Crestal minimally invasive sinus lift on severely resorbed maxillary crest: prospective study; *Biomedizinische Technik/Biomedical Engineering*, 2012, 57, ISSN (Online) 1862-278X, ISSN (Print) 0013-5585; DOI: 10.1515/bmt-2011-0038
- Crespi C., Capparié P., Gherlone E.; Sinus floor elevation by osteotome: hand mallet versus electric mallet. A prospective clinical study; *The International Journal of Oral & Maxillofacial Implants*, 2012; 27: 1144-50; DOI: 10.1111/j.1708-8208.2012.00485.x
- Al-Nsour M., Chan H. L., Wang H. L.; Effect of the platform-switching technique on preservation of peri implant marginal bone: a systematic review; *International Journal of Oral and Maxillofacial Implants*, 2012; 27: 138-145
- Annibaldi S., Bigozzi L., Cristalli M. P., Graziani F., La Monaca G., Polimeni A.; Peri-implant marginal bone level: a systematic review and meta-analysis of studies comparing platform switching versus conventionally restored implants; *Journal of Clinical Periodontology*, 2012; 39: 1097-1113; DOI: 10.1111/j.1600-051X.2012.01930.x
- Csonka M.; Switching Platform chirurgico e protesico; *Italian Dental Journal*, 2012; 08: 24
- Lang N. P., Pun L., Lau K. Y., Li K. Y., Wong M. C.; A systematic review on survival and success rates of implants placed immediately into fresh extraction sockets: after at least 1; *Clinical Oral Implants Research*, 2012; 23 (Suppl 5): 39-66; DOI: 10.1111/j.1600-0501.2011.02372.x
- Ortega Martínez J., Pérez Pascual T., Mereque Bueno S., Hernández Alfaro F., Ferrés Padró E.; Immediate Implants following tooth extraction - A systematic review; *Medicina Oral Patología Oral y Cirugía Bucal*, 2012; 17: 251-261; DOI: 10.4233/medoral.17469
- Vignoletti F., Morante Mudarra S., Lorenzo Vignau R., Oteo Pérez A., Rodrigo Gómez D.; "Implants inmediatos en alveolos postextraction. Factores críticos en la cicatrización de los tejidos duros y blandos"; *Maxillaris, Ciencia y Actualidad Profesional e Industrial del Sector Dental*, 2012, XV, 155: 110-126
- Bruschi G., Crespi R., Capparié P., Gherlone E.; Clinical study of flap design to increase the keratinized gingiva around implants. 4-year, follow-up; *Journal of Oral Implantology*, Early View, First published online in 2012, November; DOI: 10.1563/AIAD-JOI-D-11-00236.1
- Canullo L., Gotz W.; Peri-implant hard tissue response to glow-discharged abutments: Prospective study. Preliminary radiological results; *Annals of Anatomy*, 2012; 194: 174-178; DOI: org/10.1016/j.aanat.2012.03.006
- Canullo L., Micarelli C., Clementini M.; Effect of titanium abutment plasma cleaning on peri-implant bone level changes: randomized controlled trial, preliminary results; Poster, Winner, Prize Martignoni, AIOP Congress Bologna, 22-24 Novembre 2012
- Bastiani A.; espansione ossea controllata con Drill Bone Expander (D.B.E.): variabili e polifunzionalità; *Numeri Uno* 15, 2013, 10-12
- Scavia S.; Studio prospettico sul mantenimento del volume osseo verticale in impianti inseriti con tecnica M.I.S.E.; *Numeri Uno* 14, 2012, 14-15
- Crespi R., Bruschi G.B.; Vantaggi chirurgici nell'uso del Magnetic Mallet; *Numeri Uno* 13, 2012, 16-18.
- Csonka M.; Postestrativo a carico immediato con Tecnica Simple e Platform Switching; *Numeri Uno* 12, 2012, 8-9
- Minenna F., De Leo L.; Riabilitazione impianto protesica con tecnica One Stage e protesi avvitata in materiale composito; *Numeri Uno*, 12/2012, 12-13
- Micarelli C., Canullo L., Baldissara A., Clementini M.; Abutment screw removal torque values before and after plasma cleaning; *Clinical Oral Implant Research*, 2012; 23 Suppl 7: 72; DOI: 10.1111/cir.12019
- Micarelli C., Canullo L., Baldissara A., Clementini M.; Abutment screw reverse torque values before and after plasma cleaning; *International Journal of Prosthodontics*, Accepted and Overview Published online, on 12 February, 2012
- Peñarocha Diago M., Pellicer Chover H., Peñarocha Oltra D.; Rehabilitación con prótesis fija de arco completo a maxilares mandibulares sobre implantes postextraction. A propósito de un caso; *Numeri Uno* 11, 2012, 15-17
- Galli C., Piemontese M., Meikle S. T., Santini M., Macaluso G. M., Passeri G.; Biomimetic coating with phosphoserine-tethered poly(epsilon-L-lysine) dendrons on titanium surfaces enhances Wnt and osteoblastic differentiation; *Clinical Oral Implant Research*, Early View, First Published online on 2012, December 5th; DOI: 10.1111/j.1600-0501.2011.02227.x
- Bengazzi F., Lang N. P., Canciani E., Viganò P., Urbizo Velez J., Botticelli D.; Osseointegration of implants with dendrimers surface characteristics installed conventionally or with Piezosurgery®. A comparative study in the dog; *Clinical Oral Implant Research*, Early View, First Published online on 2012, December 12th; DOI: 10.1111/cir.12082
- Schweikert M., Baffone G., Botticelli D., Favero G., Lavia P. P., Lang N. P.; Influence of buccal bone crest width on marginal dimensions of peri-implant tissues after implant installation in dogs; *Clinical Oral Implant Research*, 2012; 23 Suppl 7: 77-78; DOI: 10.1111/cir.12019
- Baffone G. M., Botticelli D., Pereira F. P., Favero G., Schweikert M., Lang N. P.; Influence of buccal bone crest width on marginal dimensions of peri-implant hard and soft tissues after implant installation. An experimental study in dogs; *Clinical Oral Implants Research*, 2013; 24: 250-254; DOI: 10.1111/j.1600-0501.2012.02512.x
- Crespi R., Capparié P., Gherlone E.; A comparison of manual and electrical mallet in maxillary bone condensing for immediately loaded implants: a randomized study; *Clinical Implant Dentistry and Related Research*, Early View, First Published online on 2012, August, 15th; DOI: 10.1111/j.1708-8208.2012.00485.x
- Calvo-Guirado J. L., Boquete-Castro A., Negri B., Delgado Ruiz R., Gomez-Moreno G., Iezzi G.; Crestal bone reactions to immediate implants placed at different levels in relation to crestal bone. A pilot study in foxhound dogs; *Clinical Oral Implant Research*, Early View, First Published online on 2013, January 29th; DOI: 10.1111/cir.12110
- Scala A., Lang N. P., Schweikert M. T., de Oliveira J. A., Rangel-García I. Jr., Botticelli D.; Sequential healing of open extraction sockets. An experimental study in monkeys; *Clinical Oral Implant Research*, Early View, First Published online on 2013, April 1st; DOI: 10.1111/cir.12148
- Rossi F., Lang N. P., Favero G., Pantani F., Tschon M., Botticelli D.; Bone healing pattern at the surface of titanium implants: an experimental study in the dog; *Clinical Oral Implant Research*, 2012; 23 Suppl 7: 76-77; DOI: 10.1111/cir.12019
- Sivolella S., Bressan E., Salata L. A., Urrutia Z. A., Lang N. P., Botticelli D.; Osteogenesis at implants without primary bone contact - An experimental study in dogs; *Clinical Oral Implant Research*, 2012; 23: 542-549; DOI: 10.1111/j.1600-0501.2012.02423.x
- Sivolella S., Bressan E., Salata L. A., Quirionos M. E., Urrutia Z. A., Lang N. P., Botticelli D.; Deproteinized bovine bone mineral particles and osseointegration of implants without primary bone contact: an experimental study in dogs; *Clinical Oral Implant Research*, Early View, First Published online on 2013, April 8th; DOI: 10.1111/cir.12154
- Caneva M., Botticelli D., Viganò P., Morelli F., Rea M., Lang N. P.; Connective tissue grafts in conjunction with implants installed immediately into extraction sockets. An experimental study in dogs; *Clinical Oral Implant Research*, 2013; 24: 50-56; DOI: 10.1111/j.1600-0501.2012.02450.x
- De Santis E., Lang N. P., Cesaretti G., Mainetti T., Beolchini M., Botticelli D.; Healing outcomes at implants installed in sites augmented with particulate autologous bone and xenografts. An experimental study in dogs; *Clinical Oral Implants Research*, 2013; 24: 77-86; DOI: 10.1111/j.1600-0501.2012.02456.x
- Negri M., Lumetti S., Manfredi E., Galli C., Chiacci G., Macaluso G. M.; Marginal bone remodeling of Sweden&Martina premium implants: 2-years clinical results; *Clinical Oral Implant Research*, 2012; 23 Suppl 7: 98; DOI: 10.1111/cir.12019
- Cosyn J., Hooghe N., De Bruyn H.; A systematic review on the frequency of advanced recession following single immediate implant treatment; *Journal of Clinical Periodontology*, 2012 Jun; 39: 582-589; DOI: 10.1111/j.1600-051X.2012.01888.x
- Covani U., Chiappe G., Bosco M., Orlando B., Quaranta A., Barone A.; A 10-year evaluation of implants placed in fresh extraction sockets: a prospective cohort study; *Journal of Periodontology*, 2012; 83: 1226-1234; DOI: 10.1902/jop.2012.110583
- Covani U., Ricci M., D'Ambrosio N., Quaranta A., Barone A.; Changes in soft tissues around immediate full-arch rehabilitations: a prospective study; *Clinical Oral Implant Research*, Early View, First Published online on 2012, January, 6th; DOI: 10.1111/j.1600-0501.2011.02394.x
- Crespi R., Capparié P., Gherlone E., Romanos G.; Immediate provisionalization of dental implants placed in fresh extraction sockets using a flapless technique; *The International Journal of Periodontics & Restorative Dentistry*, 2012; 32: 29-37
- Morelli F.; Rigenerazione ossea orizzontale e verticale peri-implantare con mesh in Titanio ed osso autologo; *Numeri Uno* 11, 2011, 7-9
- Crespi R., Capparié P., Gherlone E.; Electrical mallet provides essential advantages in maxillary bone condensing. A prospective clinical study; *Clinical Implant Dentistry and Related Research*, Early View, First Published online on 2012, January, 11th; DOI: 10.1111/j.1708-8208.2011.00432.x
- Galli C., Macaluso G. M., Elezi E., Raventetti F., Cacchioli A., Gualinì G., Passeri G.; The Effects of Er:YAG Laser Treatment on Titanium Surface Profile and Osteoblastic Cell Activity: An In Vitro Study; *Journal of Periodontology*, 82 (8): 1169-1177, 2011; DOI: 10.1902/jop.2010.100428
- Ramaglia L., Postiglione L., Di Spigna G., Capece G., Salzano S., Rossi G.; Sandblasted-etched titanium surface influences in vitro the biological behavior of SaOS-2 human osteoblast-like cells; *Dental Material Journal*, 30: 183-192, 2011; DOI: 10.4012/dmj.2010-107
- Scala A., Botticelli D., Faeda R. S., Rangel I. G. Jr., de Oliveira J. A., Lang N. P.; Lack of influence of the Schneiderian membrane in forming new bone apical to implants simultaneously installed with sinus floor elevation: an experimental study in monkeys; *Clinical Oral Implant Research*, Early View, First Published online on 2011, June 13th; DOI: 10.1111/j.1600-0501.2011.02227.x
- Rossi F., Botticelli D., Pantani F., Pereira F. P., Salata L. A., Lang N. P.; Bone healing pattern in surgically created circumferential defects around submerged implants: an experimental study in dog; *Clinical Oral Implant Research*, Early View, First Published online on 2011, March 28th; DOI: 10.1111/j.1600-0501.2011.02170.x
- Caneva M., Botticelli D., Morelli F., Baffone G. M., Rangel I. G. Jr., Lang N. P.; Deproteinized bovine bone mineral in marginal defects at implants installed immediately into extraction sockets: an experimental study in dogs; *Clinical Oral Implant Research*, Early View, First Published online on 2011, May 5th; DOI: 10.1111/j.1600-0501.2011.02202.x
- De Santis E., Botticelli D., Pantani F., Pereira F. P., Beolchini M., Lang N. P.; Bone regeneration at implants placed into extraction sockets of maxillary incisors in dogs; *Clinical Oral Implant Research*, 2011; 430-437; DOI: 10.1111/j.1600-0501.2010.02122.x
- De Santis E., Lang N. P., Scala A., Viganò P., Salata L. A., Botticelli D.; Healing outcomes at implants installed in grafted sites: an experimental study in dogs; *Clinical Oral Implant Research*, Early View, First Published online on 2011, October 3rd; DOI: 10.1111/j.1600-0501.2011.02326.x
- Caneva M., Botticelli D., Morelli F., Cesaretti G., Beolchini M., Lang N. P.; Alveolar process preservation at implants installed immediately into extraction sockets using deproteinized bovine bone mineral - an experimental study in dogs; *Clinical Oral Implant Research*, Early View, First Published online on 2011, October 21st; DOI: 10.1111/j.1600-0501.2011.02332.x
- Caneva M., Botticelli D., Rossi F., Carvalho Cardoso L., Pantani F., Lang N. P.; Influence of implants with different sites and configurations installed immediately into extraction sockets on peri-implant hard and soft tissues: an experimental study in dogs; *Clinical Oral Implant Research*, Early View, First Published online on 2011, September 29th; DOI: 10.1111/j.1600-0501.2011.02310.x
- Vignoletti F., De Sanctis M., Sanz M.; Impianti immediati post-estrativi: fattori critici per la guarigione dei tessuti; *Il Dentista Moderno*, 9-94-114, 2011
- Farronato D., Santoro G., Canullo L., Botticelli D., Maiorana C., Lang N. P.; Establishment of the epithelial attachment and connective tissue adaptation to implants installed under the concept of "platform switching": a histologic study in minipigs; *Clinical Oral Implant Research*, Early View, First Published online on 2011, April 15th; DOI: 10.1111/j.1600-0501.2011.02196.x
- Baffone G. M., Botticelli D., Pantani F., Cardoso L. C., Schweikert M. T., Lang N. P.; Influence of various implant platform configurations on peri-implant tissue dimensions: an experimental study in dog; *Clinical Oral Implant Research*, 2011; 438-444; DOI: 10.1111/j.1600-0501.2010.02146.x
- Canullo L., Pellegrini G., Allievi C., Trombelli L., Annibaldi S., Delavica C.; Soft tissues around long-term platform switching implant restorations: a histological human evaluation. Preliminary results; *Journal of Clinical Periodontology*, 2011; 38: 86-94; DOI: 10.1111/j.1600-051X.2010.01641.x
- Canullo L., Iannello G., Netuschil L., Jepsen S.; Platform switching and matrix metalloproteinase-8 levels in peri-implant sulcular fluid; *Clinical Oral Implant Research*, Early View, First Published online on 2011, March 28th; DOI: 10.1111/j.1600-0501.2011.02175.x
- Della Via C., Canullo L., Allievi C., Lang N. P., Pellegrini G.; Soft tissue surrounding switched platform implants: an immunohistochemical evaluation; *Clinical Oral Implant Research*, Early View, First Published online on 2011, September 29th; DOI: 10.1111/j.1600-0501.2011.02301.x
- Baffone G. M., Botticelli D., Canullo L., Scala A., Beolchini M., Lang N. P.; Effect of mismatching abutments on implants with wide platforms - an experimental study in dogs; *Clinical Oral Implant Research*, Early View First Published online on 2011, November 2nd; DOI: 10.1111/j.1600-0501.2011.02320.x
- Canullo L., Pace F., Coelho P., Sciubba E., Vozza I.; The Influence of Platform Switching on the Biomechanical Aspects of the Implant-Abutment System. A Three Dimensional Finite Element Study; *Med Oral Patol Oral Cir Bucal*, 2011 Sep 1; 16 (6):e852-6; DOI: 10.4317/medoral.17243
- Canullo L., Iannello G., Gotz W.; The influence of individual bone patterns on peri-implant bone loss: preliminary report from a 3-year randomized clinical and histologic trial in patients treated with implants restored with matching-diameter abutments or the platform-switching concept; *International Journal of Oral & Maxillofacial Implants*, 2011 May-Jun; 26(3):618-30
- Serrano-Sánchez P., Calvo-Guirado J. L., Manzanares-Pastor E., Llorio-Castro C., Bretones-López P., Pérez-Iñanes J. A.; The influence of platform switching in dental implants. A literature review; *Medicina Oral Patología Oral Cirugía Bucal*, 2011 May 1; 16 (3):e400-5; DOI: 10.4317/medoral.16.e400
- Bruschi G. B., Crespi R., Capparié P., Bravi F., Bruschi E., Gherlone E.; Localized Management of Sinus Floor Technique for Implant Placement in Fresh Molar Sockets; *Clinical Implant Dentistry and Related Research*, 2011 May 20. [Epub ahead of print]; DOI: 10.1111/j.1708-8208.2011.00348.x
- Sisti A., Canullo L., Mottola M. P., Iannello G.; A case series on crestal sinus elevation with rotary instruments; *European Journal of Oral Implantology*, 2011 Summer; 4(2):145-52
- Garcia-Farjoto Palacios C.; Sinus Lift. Optimizzazione dei risultati; *NumeriUno* 10(06), 2011, 04-07
- Canullo L.; RIGENERAZIONE DI UN SITO POST-ESTRATTIVO con grave deficit osseo vestibolare con idrossiapatite arricchita di magnesio. CASE REPORT CON FOLLOW UP DEL RESTAURO IMPIANTO-PROTESICO A 2 ANNI; *Odontoiatria - Rivista degli Amici di Brugg*, 2012; 2: 166-167, 2011
- Becattelli A., Biscaro L., Ferlin P., Soattin M.; Riabilitazione impianto-protesica di entrambe le arcate mediante Toronto Bridge su impianti tiltati a carico immediato; *NumeriUno* 10(06) 2011, 10-12
- Ceramico G., Tomarelli F.; Carico implantare immediato e condizionamento dei tessuti molli con provvisorio in ceramica; *NumeriUno* 10 (06) 2011, 18-21
- Avanzo P., Fabrocini L., Avanzo A., Ciavarella D., Lo Muzio L.; Use of intra-oral welding to stabilize dental implants in augmented sites for immediate provisionalization: a case report; *Journal of Oral Implantology*, 2010 Oct 8. [Epub ahead of print]; DOI: 10.1563/AIAD-JOI-D-10-00047
- Dominici A. D.; Solidificazione elettronica su impianti a carico immediato: un caso clinico in chirurgia flapless; *Dental Cadmos*, 79(8):545-550, 2011; DOI: 10.1016/j.cadmos.2011.03.002
- De Paolis G., Quaranta A., Zappia S., Vozza I., Quaranta M.; Valutazione clinica e microbiologica di impianti a connessione conometrica rispetto a impianti a connessione esagonale: caso clinico; *Dental Cadmos*, 79(7):443-451, 2011; DOI: 10.1016/j.cadmos.2010.12.010
- Canullo L., Bigozzi L., Cocchetto R., Cristalli M. P., Iannello G.; Immediate positioning of a definitive abutment versus repeated abutment replacements in post-extractive implants: 3-year follow-up of a randomized multicenter clinical trial; *European Journal of Oral Implantology*, 2010 Winter; 3(4):285-96
- Csonka M.; Carico Immediato di una Cresta Mandibolare Edentula con Tecnica SIMPLE; *Italian Dental Journal*, 2011
- Canullo L., Baffone G. M., Botticelli D., Pantani F., Beolchini M., Lang N. P.; Effect of wider implant/abutment mismatching: an histological study in dogs; *Clinical Oral Implant Research*, 22(9), 2011; 910-910; DOI: 10.1111/j.1600-0501.2011.02271.x
- Rossi F., Botticelli D., Salata L.; Bone healing in animal surgically created circumferential defects around submerged implants; *Clinical Oral Implant Research*, 22(9), 2011; 937; DOI: 10.1111/j.1600-0501.2011.02271.x
- Ricci M., Funel N., Orazio V., Bobbio A., Barone A., Covani U.; Analysis of osteoblastic gene dynamics in the early human mesenchymal cell response to an implant support: an in vitro study; *Clinical Oral Implant Research*, 22(9), 2011; 1071; DOI: 10.1111/j.1600-0501.2011.02271.x
- Canullo L., Gotz W.; Cell growth on titanium disks treated by plasma of Argon: experimental study; *Clinical Oral Implant Research*, 22(9), 2011; 1082-3; DOI: 10.1111/j.1600-0501.2011.02271.x
- Bruschi G. B., Crespi R.; TECNICHE DI ESPANSIONE OSSEA IN CHIRURGIA IMPLANTARE; *Quintessenza Edizioni S.r.l.*, 2011, Milano (Anteprima)
- Avellino W., Milan U., Delle Rose D.; SOLUZIONI CLINICHE E TECNICHE PER LA REALIZZAZIONE DI UN PROVVISORIO FULL-ARCH SU IMPIANTI CON FUNZIONE IMMEDIATA; *NumeriUno*, 7: 11-13, 2010
- Branci R., Vangi D., Virga A., Guertin G., Fazi G.; RESISTANCE TO WEAR OF FOUR MATRICES WITH BALL ATTACHMENTS FOR IMPLANT OVERDENTURES: A FATIGUE STUDY; *Journal of Prosthodontics*, 19(8):614-619, 2010
- Bruschi G. B., Crespi R., Capparié P., Gherlone E.; TRANS-CRESTAL SINUS FLOOR ELEVATION: A RETROSPECTIVE STUDY OF 46 PATIENTS UP TO 16 YEARS; *Clinical Oral Implant Dentistry and Related Research*, 2010 Oct 26
- Caneva M., Salata L. A., Scombatti de Souza S., Baffone G., Lang N. P., Botticelli D.; INFLUENCE OF IMPLANT POSITIONING IN EXTRACTION SOCKETS ON OSSEointegration: HISTOMORPHOMETRIC ANALYSES IN DOGS; *Clinical Oral Implant Research* 21; 43-49, 2010
- Caneva M., Salata L. A., Scombatti de Souza S., Bressan E., Botticelli D., Lang N. P.; HARD TISSUE FORMATION ADJACENT TO IMPLANTS OF VARIOUS SIZE AND CONFIGURATION IMMEDIATELY PLACED INTO EXTRACTION SOCKETS: AN EXPERIMENTAL STUDY IN DOGS; *Clinical Oral Implant Research*, 21(9):885-90, 2010
- Caneva M., Botticelli D., Stellini E., Souza S. L., Salata L. A., Lang N. P.; MAGNESIUM-ENRICHED HYDROXYAPATITE AT IMMEDIATE IMPLANTS: A HISTOMORPHOMETRIC STUDY IN DOGS; *Clinical Oral Implant Research*, Early View, First Published online on 2010, December 10th
- Caneva M., Botticelli D., Salata L. A., Scombatti de Souza S., Carvalho Cardoso L., Lang N. P.; COLLAGEN MEMBRANES AT IMMEDIATE IMPLANTS: A HISTOMORPHOMETRIC STUDY IN DOGS; *Clinical Oral Implant Research*, 21(9):891-7, 2010
- Caneva M., Botticelli D., Salata L. A., Scombatti de Souza S. L., Bressan E., Lang N. P.; FLAP VS. "FLAPLESS" SURGICAL APPROACH AT IMMEDIATE IMPLANTS: A HISTOMORPHOMETRIC STUDY IN DOGS; *Clinical Oral Implant Research*, 21 (12):1314-1319, 2010
- Canullo L., Quaranta A., Teles R. P.; THE MICROBIOTA ASSOCIATED WITH IMPLANTS RESTORED WITH PLATFORM SWITCHING: A PRELIMINARY REPORT; *Journal of Periodontology*, 81:403-411, 2010



Canullo L, Rossi Fedele G, Iannello G, Jepsen S; PLATFORM SWITCHING AND MARGINAL BONE-LEVEL ALTERATIONS: THE RESULTS OF A RANDOMIZED CONTROLLED TRIAL; *Clinical Oral Implants Research*, 21:115-121, 2010

Canullo L, Bignozzi I, Cocchetto R; "ONE ABUTMENT-ONE TIME": OPTIMIZING PLATFORM-SWITCHING CONCEPT. THREE-YEAR CONTROLLED PROSPECTIVE STUDY; *Clinical Oral Implants Research*, 21 (10): 1085, 2010

Canullo L; CASO CLINICO: AGENESIA DELL'INCISIVO LATERALE SUPERIORE DESTRO; *Italian Dental Journal*, 4: 16, 2010

Canullo L, Cocchetto R, Loi I; PERI-IMPLANT TISSUES REMODELING: SCIENTIFIC BACKGROUND & CLINICAL IMPLICATIONS; *Quintessenza Edizioni S.r.l.*, 2010, Milano (Anteprima)

Canullo L, Sisti A; EARLY IMPLANT LOADING AFTER VERTICAL RIDGE AUGMENTATION (VRA) USING E-PFTE TITANIUM REINFORCED MEMBRANE AND NANOSTRUCTURED HYDROXYAPATITE: 2-YEAR PROSPECTIVE STUDY; *European Journal Oral Implantology*, 3(1):59-69, 2010

Canullo L, Patacchia O, Sisti A, Heinemann F; IMPLANT RESTORATION 3 MONTHS AFTER ONE STAGE SINUS LIFT SURGERY IN SEVERELY RESORBED MAXILLAE: 2-YEAR RESULTS ON A MULTICENTER PROSPECTIVE CLINICAL STUDY; *Clinical Implant Dentistry and Related Research*, Early view - Published online in ahead of printing, 21-10-2010

Ciccù M., Ristano G., Maiorana C., Herford A., Otteri G., Ciccù D. "TORONTO" SCREWED MANDIBULAR OVERDENTURE ON DENTAL IMPLANTS: FEM AND VON MISES ANALYSIS OF STRESS DISTRIBUTION; *The Journal of Implants and Advanced Dentistry*, 2(9): 41-58, 2010

Covani U, Marconcini S, Santini S, Cornelini R, Barone A; IMMEDIATE RESTORATION OF SINGLE IMPLANTS PLACED IMMEDIATELY AFTER IMPLANT REMOVAL. A CASE REPORT; *International Journal of Periodontics & Restorative Dentistry*, 30:639-645, 2010

Crespi R, Cappare P, Gherlone E; OSTEOOME SINUS FLOOR ELEVATION AND SIMULTANEOUS IMPLANT PLACEMENT IN GRAFTED BIOMATERIAL SOCKETS: 3 YEARS OF FOLLOW-UP; *Journal of Periodontology*, 81:344-349, 2010

Crespi R, Cappare P, Gherlone E; A 4-YEAR EVALUATION OF THE PERI-IMPLANT PARAMETERS OF IMMEDIATE LOADED IMPLANTS PLACED IN FRESH EXTRACTION SOCKETS; *Journal of Periodontology*, 81 (11):1629-1634, 2010

Crespi R, Cappare P, Gherlone E; IMMEDIATE LOADING OF DENTAL IMPLANTS PLACED IN PERIODONTALLY INFECTED AND NON-INFECTED SITES IN HUMANS: A FOUR YEARS FOLLOW-UP CLINICAL STUDY; *Journal of Periodontology*, 81 (8):1140-1146, 2010

Crespi R, Cappare P and Gherlone E; FRESH-SOCKET IMPLANTS IN PERIAPICAL INFECTED SITES IN HUMANS; *Journal of Periodontology*, 81:378-383, 2010

Galli C, Passeri G, Piemontese M, Lumetti S, Manfredi E, Carra M.C., Macaluso G.M.; PHOSPHOSERINE-POLY (LYSINE) COATINGS PROMOTE OSTEOBLASTIC DIFFERENTIATION AND WNT SIGNALING ON TITANIUM SUBSTRATES; *Clinical Oral Implants Research*, 21(10): 1172, 2010

Mantano G; LE CORONE PROVVISORIE IMMEDIATE SU IMPIANTI GLOBAL (METODICA CLINICA); *NumeriUno*, 7: 17-18, 2010

Momen A., Hadeel M. I., Ahmad H. A.; PLATFORM SWITCHING FOR MARGINAL BONE PRESERVATION AROUND DENTAL IMPLANTS: A SYSTEMATIC REVIEW AND META-ANALYSIS; *Journal of Periodontology*, 81 (10):1350-1366, 2010

Pantani F., Botticelli D., Rangel Garcia J. R., Salata L. A., Jayme Borges G., Lang N. P.; INFLUENCE OF LATERAL PRESSURE TO THE IMPLANT BED ON OSSEointegration: AN EXPERIMENTAL STUDY IN DOGS; *Clinical Oral Implants Research*, 21(11): 1264-70, 2010

Passeri G, Caccioli A., Ravanetti F, Galli C, Elezi E, Macaluso G.M.; ADHESION PATTERN AND GROWTH OF PRIMARY HUMAN OSTEOBLASTIC CELLS ON FIVE COMMERCIALY AVAILABLE TITANIUM SURFACES; *Clinical Oral Implants Research* 21: 756-765, 2010

Raddi F; ANALISI COMPARATIVA TEST DI RESISTENZA A FATICA SPERIMENTALI E VIRTUALI; *Relazione interna*, Sweden & Martina, 2010

Scala A., Botticelli D., Oliveira J.A., Okamoto R., Garcia Rangel I. Jr., Lang N.P.; EARLY HEALING AFTER ELEVATION OF THE MAXILLARY SINUS FLOOR APPLYING A LATERAL ACCESS - A HISTOLOGICAL STUDY IN MONKEYS; *Clinical Oral Implants Research*, 21 (12): 1320-6, 2010

Silvasan M.H.; TIMING OF DENTAL IMPLANT LOADING - A LITERATURE REVIEW; *Implants - Oemus*, 11 (3): 06-16, 2010

Sbordone L, Levin L, Guidetti F, Sbordone C, Gilman A, Schwartz-Arad D; APICAL AND MARGINAL BONE ALTERATIONS AROUND IMPLANTS IN MAXILLARY SINUS AUGMENTATION GRAFTED WITH AUTOGENOUS BONE OR BOVINE BONE MATERIAL AND SIMULTANEOUS OR DELAYED DENTAL IMPLANT POSITIONING; *Clinical Oral Implants Research*, 2010 Nov 19. [Epub ahead of print]

Ballini D, Attini M, Giunta S, Mezzanotte E; MINI IMPIANTI: UN CASE REPORT; *NumeriUno*, 5: 18-20, 2009

Biscaro L, Becatelli A, Soattin M.; RIABILITAZIONE IMPLANTO-PROTESICA DELLE DUE ARCADE CON CARICO IMMEDIATO: PROTOCOLLO DI LAVORO CON L'UTILIZZO DELLA TECNICA DEL MODELLO UNICO E DELLA SISTEMATICA PAD; *NumeriUno*, 8, 04-05, 2009

Briguglio F, Briguglio E, Sidoti Pinto G.A., Lapi M., Zappia D.; VALUTAZIONE CLINICA COMPARATIVA SULL'UTILIZZO DI UN COPOLIMERO DELL'ACIDO POLIGLICOLICO E POLILATTICO NEL SINUS LIFT; *Implantologia*, 1:9-14, 2009

Bruschi G. B., Bravi F., Di Felice A.; RIABILITAZIONE PROTETICA SU DENTI E IMPIANTI MEDIANTE TECNICHE CHIRURGICHE DI ESPANSIONE CRESTALE E SOLLEVAMENTO DEL SENO E CHIRURGIA PROTETICAMENTE GUIDATA; *NumeriUno*, 5: 8-14, 2009

Calesini G., Micarelli C., Coppe S., Scipioni A.; EDENTOLOUS SITE ENHANCEMENT: A REGENERATIVE APPROACH TO THE MANAGEMENT OF EDENTULOUS AREAS. PART 2: PERI-IMPLANT TISSUES; *International Journal of Periodontics & Restorative Dentistry*, 29(1):49-57, 2009

Canullo L, Iurlaro G., Iannello G.; DOUBLE-BLIND RANDOMIZED CONTROLLED TRIAL STUDY ON POSTEXTRACTION IMMEDIATELY RESTORED IMPLANTS USING THE SWITCHING PLATFORM CONCEPT: SOFT TISSUE RESPONSE. PRELIMINARY REPORT; *Clinical Oral Implants Research*, 20 (4):414-420, 2009

Canullo L, Goglia G., Iurlaro G., and Iannello G.; SHORT-TERM BONE LEVEL OBSERVATIONS ASSOCIATED WITH PLATFORM SWITCHING IN IMMEDIATELY PLACED AND RESTORED SINGLE MAXILLARY IMPLANTS: A PRELIMINARY REPORT; *International Journal of Prosthodontics*, 22 (3):277-282, 2009

Canullo L, Iannello G., Jepsen S.; MATRIX-METALLOPROTEINASES AND BONE LOSS AT IMPLANTS RESTORED ACCORDING TO THE PLATFORM SWITCHING CONCEPT: A RANDOMIZED CONTROLLED TRIAL ON THE INFLUENCE OF DIFFERENT MISMATCHING; *Clinical Oral Implants Research*, 20(9):873-874, 2009

Canullo L, Vozza I., Caricato F., Dellavica C.; MAXILLARY SINUS FLOOR AUGMENTATION USING A NANOCRYSTALLINE HYDROXYAPATITE SILICA GEL. A PROSPECTIVE STUDY - HISTOLOGICAL RESULTS AFTER 3 MONTHS OF HEALING; *Implants*, 2, 24-27, 2009

Cardelli P., Montani M., Gallo M., Biancolini M., Brutti C., Barlattani A.; ABUTMENTS ANGLATI E TENSIONI PERIMPLANTARI: ANALISI F.E.M.; *Oral Implantology*, 1:7-14, 2009

Carini F., Guidi R., Franco M., Viscioni A., Rigo L., De Santis B., Tropina E.; IMPLANTS INSERTED IN FRESH-FROZEN BONE: A RETROSPECTIVE ANALYSIS OF 89 IMPLANTS LOADED 4 MONTHS AFTER INSERTION; *Quintessenza International*, 40(5): 413-419, 2009

Carusi G., Sisti A., Mottola M.P., Matera G., Veruggio P., Gelmi L., Bailo A.; TECNICA DI RIALZO DI SENO MINIMAMENTE INVASIVA NEL TRATTAMENTO IMPLANTARE DEL MASCELLARE EDENTULO; *Dental Cadmos*, 77(10): 31-40, 2009

Ceccherini A., De Angelis L., Silvestrelli S.; CHIRURGIA SOFTWARE ASSISTITA CON LA TECNICA MODEL GUIDE: PROGETTO 3D - POSA DELL'IMPIANTO GUIDATA; *TeamWork*, 11(6), 63-75, 2009

Ciccù M., Ristano G., Maiorana C., Franceschini G.; PARAMETRIC ANALYSIS OF THE STRENGTH IN THE "TORONTO" OSSEOUS-PROSTHESIS SYSTEM; *Minerva Stomatologica*, 58(1):29-33, 2009

Covani U; I VANTAGGI DELL'IMPIANTO PREMIUM/KOHN NELLA CHIRURGIA SOSTITUITIVA DELL'ARCCA DENTARIA; Atti del Congresso, X Congresso Nazionale di Implantoprotesi Integrata Premium Day 2009, 18-20 giugno 2009, Abano Terme, pp. 14-15

Crespi R., Cappare P., Gherlone E.; RADIOGRAPHIC EVALUATION OF MARGINAL BONE LEVELS AROUND PLATFORM-SWITCHED AND NON-PLATFORM-SWITCHED IMPLANTS USED IN AN IMMEDIATE LOADING PROTOCOL; *The International Journal of Oral and Maxillofacial Implants*, 24:920-926, 2009

Crespi R., Cappare P., Gherlone E.; DENTAL IMPLANTS PLACED IN EXTRACTION SITES GRAFTED WITH DIFFERENT BONE SUBSTITUTES: RADIOGRAPHIC EVALUATION AT 24 MONTHS; *Journal of Periodontology*, 80 (10):1616-1621, 2009

Figiuzzi M.; LA TECNICA FLAPLESS: INDICAZIONI E LIMITI; *NumeriUno*, 3 (12-3); 2009, 04-07

Lenz C.; LA RIGENERAZIONE DEI DIFFETTI OSSEI NEI SITI POSTESTRATTIVI MEDIANTE OSO BOVINO DEPROTEINIZZATO. VALUTAZIONE DELLE DIFFERENTI TECNICHE CHIRURGICHE; *Implantologia*, 1: 51-59, 2009

Maiorana C., Ciccù M., Andreoni D., Beretta M.; CARICO IMMEDIATO DI DENTE SINGOLO: CASO CLINICO E REVISIONE DELLA LETTERATURA; *Journal of Osseointegration*, 2(1): 1-10, 2009

Maiorana C., Ciccù M., Beretta M., Andreoni D.; RISULTATI DEL TRATTAMENTO CON CARICO FUNZIONALE PRECOCE SU PROTESI TORONTO DOPO IL POSIZIONAMENTO DI IMPIANTI IN SITI POSTESTRATTIVI; *Journal of Osseointegration*, 2(1): 95-100, 2009

Mazzella M., Prota V., Mazzella A.; IL PONTIC A CONFORMAZIONE OVOIDALE IN PROTESI IMPIANTARE; *NumeriUno*, 6: 6-7, 2009

Monguzzi R., Pozzi E., Franceschini F. G.; PROTESI IN ZIRCONIO SU IMPIANTI ED ELEMENTI NATURALI; *NumeriUno*, 6, 04-05, 2009

Panic G.; L'UTILIZZO DELLA TECNOLOGIA CAD-CAM ECHO PER IL TRATTAMENTO PROTETICO DI TIPO CEMENTATO DELLE EDENTULIE SINGOLE IN ZONA ESTETICA; *NumeriUno*, 4 (4-6):04-05, 2009

Quaranta A., Maida C., Scarscia A., Campus G., Quaranta A.; ER:YAG LASER APPLICATION ON TITANIUM IMPLANT SURFACES CONTAMINATED BY PORPHYROMONAS GINGIVALIS: AN HISTOMORPHOMETRIC EVALUATION; *Minerva Stomatologica*, 58:317-30, 2009

Ricci M., Tonelli P., Barone A., Covani U.; RUOLO DEL PLATFORM SWITCHING NEL MANTENIMENTO DELL'OSO PERIMPLANTARE; *Dental Cadmos*, 77(9): 31-39, 2009

Sevati G.; CARICO PRECOCE DI IMPIANTI DENTALI CHE SOSTENGONO UNA PROTESI FISSA NELLA MANDIBOLA POSTERIORE EDENTULA; *NumeriUno*, 4: 6-8, 2009

Barone A., Cornelini R., Ciaglia R., Covani U.; IMPLANT PLACEMENT IN FRESH EXTRACTION SOCKETS AND SIMULTANEOUS OSTEOOME SINUS FLOOR ELEVATION: A CASE SERIES; *International Journal of Periodontics Restorative Dentistry*, 28(3):283-9, 2008

Bosio C.; CARICO IMMEDIATO MANDIBOLARE; *NumeriUno*, 0: 7-9, 2008

Canullo L, Malagnino G., Iurlaro G.; RIABILITAZIONE PROTETICA DI IMPIANTI SINGOLI A CARICO IMMEDIATO: STUDIO PROSPETTICO; *Dental Cadmos*, 76(6): 1-8, 2008

Canullo L, Nuzzoli A., Marinotti F.; TECNICHE DI REALIZZAZIONE DI UN PROVVISORIO SU MONOIMPIANTO A CARICO IMMEDIATO; *Implantologia*, 1: 21-29, 2008

Canullo L; PLATFORM SWITCHING E CARICO IMMEDIATO SUL DENTE SINGOLO IN ZONA ESTETICA; *NumeriUno*, 1: 6-7, 2008

Ciccù M., Beretta M., Ristano G., Maiorana C.; CEMENTED-RETAINED VS SCREW-RETAINED IMPLANT RESTORATIONS: AN INVESTIGATION ON 1939 DENTAL IMPLANTS; *Minerva Stomatol.*, 57(4):167-79, 2008

Covani U, Barone A., Cornelini R.; BUCCAL BONE AUGMENTATION AROUND IMMEDIATE IMPLANTS WITH AND WITHOUT FLAP ELEVATION: A MODIFIED APPROACH; *International Journal Oral and Maxillofacial Implants*, 23:841-846, 2008

Crespi R.; CARICO IMMEDIATO IN IMPLANTOPROTESI. PROTOCOLLI SPERIMENTALI E APPLICAZIONI CLINICHE; *Quintessenza Edizioni S.r.l.*, 2008, Milano

Crespi R., Cappare P., Gherlone E., Romanos G.E.; IL CARICO IMMEDIATO IN IMPIANTI POSTESTRATTIVI IMMEDIATI; *Implantologia*, anno 6, marzo 2008

Crespi R., Cappare P., Gherlone E., Romanos G.E.; IMMEDIATE VERSUS DELAYED LOADING OF DENTAL IMPLANTS PLACED IN FRESH EXTRACTION SOCKETS IN THE MAXILLARY ESTHETIC ZONE: A CLINICAL COMPARATIVE STUDY; *International Journal of Oral Maxillofacial Implants*, 23:753-758, 2008

Lenzi C. C.; LA RIABILITAZIONE IMPLANTOPROTESICA FUNZIONALE ED ESTETICA CON SINUS LIFT MONOLATERALE. CASE REPORT; *Implantologia*, 4:63-65, 2008

Ristano G., Franceschini G., Ciccù M., Maiorana C.; ANALISI PARAMETRICA DELL'EFFICIENZA DEL SISTEMA PROTESI TIPO "TORONTO"; XXXVII Convegno Nazionale, ANAIS Associazione Italiana per l'Analisi delle Collezioni, 10-13 settembre 2008, Università di Roma La Sapienza, Atti del Congresso

Scipioni A., Calesini G., Micarelli C., Coppe S., Scipioni L.; MORPHOGENIC BONE SPLITTING: DESCRIPTION OF AN ORIGINAL TECHNIQUE AND ITS APPLICATION IN AESTHETICALLY SIGNIFICANT AREAS; *The International Journal of Prosthodontics*, 21(5):389-397, 2008

Tagliani M., Morandini E.; RIABILITAZIONE IMPLANTO-PROTESICA BIMASCELLARE DI UN PAZIENTE CON GRAVE ATROFIA OSSEA MEDIANTE TECNICA DI ESPANSIONE CRESTALE ASSOCIATA A CARICO IMMEDIATO NELL'ARCCA INFERIORE E A RIALZO DI SENO MASCELLARE LOCALIZZATO CON APPROCCIO CRESTALE; *NumeriUno*, 2(10-12):04-06, 2008

Covani U, Marconcini S., Galassi G., Cornelini R., Santini S., Barone A.; CONNECTIVE TISSUE GRAFT USED AS A BIOLOGIC BARRIER TO COVER AN IMMEDIATE IMPLANT; *Journal of Periodontology*, 78:1644-1649, 2007

Covani U., Barone A., Cornelini R.; VERTICAL CRESTAL BONE CHANGES AROUND IMPLANTS PLACED INTO FRESH EXTRACTION SOCKETS; *Journal of Periodontology*, 78:810-815, 2007

Crespi R., Cappare P., Gherlone E., Romanos G.E.; IMMEDIATE OCCLUSAL LOADING OF IMPLANTS PLACED IN FRESH SOCKETS AFTER TOOTH EXTRACTION; *International Journal of Oral Maxillofacial Implants*, 22:952-962, 2007

Elezi E., Galli C., Passeri G., Lumetti S., Manfredi E., Bonanini M., Macaluso G.M.; IL COMPORTAMENTO DEGLI OSTEOBLASTI UMANI SU SUPERFICI DI TITANIO TRATTATE IN MODO DIVERSO; *ADR General Session & Exhibition - Abstract Collection*, 2007

Pappalardo S., Milazzo I., Nicoletti G., Baglio O., Blandino G., Scalinì L., Mastrangelo F., Tete S.; DENTAL IMPLANTS WITH LOCKING TAPER CONNECTION VERSUS SCREWED CONNECTION: MICROBIOLOGIC AND SCANNING ELECTRON MICROSCOPE STUDY; *International Journal of Immunopathologic Pharmacology*, 20 (Suppl1) Jan-Mar; 13-17, 2007

Ravasinì T., Malaguti G., Coppi C., Bortolini S., Consolo U.; APPLICAZIONE CLINICA DI UN NUOVO IMPIANTO CORTO; *Dental Cadmos*, 6: 57-62, 2007

Barone A., Rispoli L., Vozza I., Quaranta A., Covani U.; IMMEDIATE RESTORATION OF SINGLE IMPLANTS PLACED IMMEDIATELY AFTER TOOTH EXTRACTION; *Journal of Periodontology*, 77 (11):1914-1920, 2006

Barone A., Santini S., Sbordone L., Crespi R., Covani U.; A CLINICAL STUDY OF THE OUTCOMES AND COMPLICATIONS ASSOCIATED WITH MAXILLARY SINUS AUGMENTATION; *International Journal of Oral Maxillofacial Implants*, 21(11):81-5, 2006

Covani U., Barone A., Cornelini R., Crespi R.; CLINICAL OUTCOME OF IMPLANTS PLACED IMMEDIATELY AFTER IMPLANT REMOVAL; *Journal of Periodontology*, 77:722-727, 2006

Pettilio N.; CARICO IMMEDIATO POST-ESTRATTIVO SU MONOIMPIANTI MASCELLARI; *Dental Cadmos*, 8:37-45, 2006

Sbordone L., Guidetti F., Menchini Fabris G.B., Sbordone C.; LANGERHANS' CELL HISTIOCYTOSIS: A CASE REPORT OF AN EOSINOPHILIC GRANULOMA OF THE MANDIBLE TREATED WITH BONE GRAFT SURGERY AND ENDOSEOUS TITANIUM IMPLANTS; *International Journal of Oral and Maxillofacial Implants*, 21: 124-130, 2006

Seganti P.; TORONTO IN FIBRA, UN'ALTERNATIVA MODERNA; *Quintessenza Odontotecnica*, 3:30-38, 2006

Barone A., Crespi R., Santini S., Cornelini R., Covani U.; RIALZO DEL SENO MASCELLARE IN CASI DI SPLIT MOUTH: OSSERVAZIONI ISTOLOGICHE; *Italian Oral Surgery*, 2: 19-24, 2005

Conserva E., Tealdo I., Acquaviva A., Bevilacqua E., Volpara G., Pera P.; ANALISI MORFOLOGICA E VALUTAZIONE DELLA PROLIFERAZIONE CELLULARE IN REAZIONE A DIFFERENTI TRATTAMENTI DI SUPERFICIE IMPLANTARE: STUDIO IN VITRO; *Implantologia*, 4: 303-317, 2005

Covani U., Barone A., Marconcini S., Cornelini R.; IMPIANTI POST-ESTRATTIVI A PROTESIZZAZIONE IMMEDIATA. STUDIO CLINICO PRELIMINARE; *Implantologia Orale*, 5 (11): 40-45, 2005

Pappalardo S., Baglio O.A., Carlino P., Grassi F.R.; INDAGINE AL MICROSCOPIO ELETTRONICO A SCANSIONE DI DIVERSE SUPERFICIE IMPLANTARI: STUDIO COMPARATIVO; *European Journal of Implant Prosthodontics*, 1 (1): 25-34, 2005

Riley D., Bavastrello V., Covani U., Barone A., Nicolini C.; AN IN-VITRO STUDY OF THE STERILIZATION OF TITANIUM DENTAL IMPLANTS USING LOW INTENSITY UV-RADIATION; *Dental materials*; official publication of the Academy of Dental Materials, 21 (8): 756-60, 2005

Barone A., Ameri S., Santini S., Covani U.; GUARIGIONE OSSEA MARGINALE IN IMPIANTI POSTESTRATTIVI IMMEDIATI; *Implantologia Orale*, 5 (11): 37-40, 2004

Barone A., Santini S., Covani U.; IMPIANTI POST-ESTRATTIVI IMMEDIATI. STUDIO LONGITUDINALE A 4 ANNI. RISULTATI PRELIMINARI; *Il Circolo, Rivista Periodica di Odontostomatologia*, 1: 7-11, 2004

Barone A., Ameri S., Santini S., Covani U.; IMPIANTI POST-ESTRATTIVI SENZA LEMBO CHIRURGICO: GUARIGIONE DEI TESSUTI MOLLI; *DoctorOs*, 15 (3): 223-227, 2004

Bruschi G.B.; TECNICA DI ESPANSIONE VERTICALE DELLA CRESTA EDENTULA CON DISLOCAMENTO DEL PAVIMENTO DEL SENO MASCELLARE; *Implantologia Orale*, 3 (5): 9-24, 2004

Calesini G., Scipioni A.; RITRATTAMENTO IMPLANTARE: RIFLESSIONI SU UN CASO CLINICO; *Il Circolo, Rivista Periodica di Odontostomatologia*, 1: 21-26, 2004

Carini F., Pezzetti F., Volinia S., Francioso F., Arcelli D., Marchesini J., Caramelli E., Piattelli A.; ANALYSIS OF MGB3 OSTEOBLAST-CELL RESPONSE TO A NEW NANOPOROUS IMPLANT SURFACE BY MEANS OF A MICROARRAY TECHNOLOGY; *Clinical Oral Implants Research*, 15: 180-186, 2004

Cassetta M., Dell'Aquila D., Calasso S., Quaranta A.; LA MODULAZIONE DEI TEMPI DELLA TERAPIA IMPLANTARE. ANALISI DELLA FREQUENZA DI RISONANZA (AFF); *Dental Cadmos*, 1: 1-30, 2004

Covani U., Barone A., Cornelini R., Crespi R.; SOFT TISSUE HEALING AROUND IMPLANTS PLACED IMMEDIATELY AFTER TOOTH EXTRACTION WITHOUT INCISION: A CLINICAL REPORT; *The International Journal of Oral and Maxillofacial Implants*, 19(4): 549-553, 2004

Covani U., Crespi R., Cornelini R., Barone A.; IMMEDIATE IMPLANTS SUPPORTING SINGLE CROWN RESTORATION: A 4-YEAR PROSPECTIVE STUDY; *Journal of Periodontology*, 75(7):982-8, 2004

Covani U. and Bertolaya C., Barone A., Sbordone L.; BUCCO-LINGUAL CRESTAL BONE CHANGES AFTER IMMEDIATE ORAL IMPLANT PLACEMENT; *Journal of Periodontology*, 75(12):1605-12, 2004

Morra M., Cassinelli C., Crespi R., Covani U.; VALUTAZIONE IN VITRO DI UNA NUOVA SUPERFICIE IMPLANTARE CON MORFOLOGIA NANO-STRUTTURATA; *Il Circolo, Rivista Periodica di Odontostomatologia*, 1: 27-34, 2004

Perrotti V., Scarano A., Iezzi G., Piattelli A.; RISPOSTA OSSEA AD IMPIANTI A SUPERFICIE ANODIZZATA; *Il Circolo, Rivista Periodica di Odontostomatologia*, 1: 13-20, 2004

Postiglione L., Di Domenico G., Ramaglia L., Lauri A.E., Di Meglio F., Montagnani S.; DIFFERENT TITANIUM SURFACES MODULATE THE BONE PHENOTYPE OF SAOS-2 OSTEOBLAST-LIKE CELLS; *European Journal of Histochemistry* 49 (3): 213-222, 2004

Bellabona G.; IMPIANTO POST-ESTRATTIVO CON INNESCO DI OSO AUTOLOGO E MEMBRANA NON RIASSORBIBILE; *Il Dentista Moderno*, 7 (9): 121-126, 2003

Biancolini M., Brutti C.; STUDIO COMPARATIVO DEL COMPORTAMENTO MECCANICO DI QUATTRO IMPIANTI; *Relazione interna*, Sweden & Martina, 15 gennaio 2003

Cassetta M., Vozzolo S.V., Stasolla A., Marini M.; LA RISONANZA MAGNETICA NELLA VALUTAZIONE PREIMPLANTARE; *Dental Cadmos*, 3: 19-37, 2003

Covani U., Cornelini R., Barone A.; BUCCO-LINGUAL BONE REMODELING AROUND IMPLANTS PLACED INTO IMMEDIATE EXTRACTION SOCKETS: A CASE SERIES; *Journal of Periodontology*, 74(2):268-73, 2003

Covani U., Barone A., Cornelini R., Gherlone E.; RADIOGRAPHIC BONE DENSITY AROUND IMMEDIATELY LOADED ORAL IMPLANTS; *Clinical Oral Implants Research*, nr. 14 (5): 610-615, 2003

Marzo G., Di Martino S., Marchetti E., Mummolo S.; VALUTAZIONE RETROSPETTIVA DELLA METODICA IMPLANTARE POSTESTRATTIVA: 10 ANNI DI OSSERVAZIONE; *Doctor Os*, 14 (4): 366-379, 2003

Masolini P.; IMPIANTO POSTESTRATTIVO IMMEDIATO; *Il Dentista Moderno*, 4: 115-122, 2003

Postiglione L., Di Domenico G., Ramaglia L., Montagnani S., Salzano S., Di Meglio F., Sbordone L., Vitale M., Rossi G.; BEHAVIOR OF SAOS-2 CELLS CULTURED ON DIFFERENT TITANIUM SURFACES; *Journal of Dental Research*, 82 (9): 692-696, 2003

Scarano A., Iezzi G., Petrone G., Quaranta A., Piattelli A.; VALUTAZIONE DELLA DENSITA' OSSEA PERIMPLANTARE: UNO STUDIO SPERIMENTALE SU CONIGLIO; *Il Dentista Moderno*, 5:95-107, 2003

Covani U., Barone A., Cornelini R.; RIALZO DEL SENO MASCELLARE UTILIZZANDO PLASMA RICCO DI PIATRINE E SOLFATO DI CALCIO; *Doctor Os*, 6: 725-730, 2002

Covani U., Barone A.; IMPIANTI IMMEDIATI E PLASMA RICCO DI PIATRINE: CASO CLINICO; *Dental Cadmos*, 10: 79-85, 2002

Cilenti C., Grasso G., Pincò S., Pulvirenti G.; SISTEMA COMBINATO PER LA CARATTERIZZAZIONE A FATICA DI MATERIALI IMPLANTOLOGICI E PROTETICI; *Relazione interna*, Università di Catania, 2001

Conforti A., Madini G.; MONO IMPIANTI: REALIZZAZIONI PROTETICHE CON L'AUSILIO DI VETROPOLIMERI OCCLUSI FUNZIONALI; *Rassegna Odontotecnica*, 9: 33-48, 2000

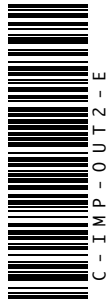

Rev. 11-14



www.sweden-martina.com

Sweden & Martina S.p.A.
Via Veneto, 10 - 35020 Due Carrare (PD), Italy
Tel. +39.049.9124300
Fax +39.049.9124290

info@sweden-martina.com

Sweden & Martina Mediterranea S.L.
Sorolla Center, Oficina 801
Av.da Cortes Valencianas 58, 8pl -46015-Valencia, España
Tel. +34.96.3525895

info.es@sweden-martina.com
Numero gratuito 900993963

Except when indicated in the internal pages, the implants, the prosthetic components and the surgical subject of this catalogue are Medical Devices manufactured by Sweden & Martina S.p.A. , they conform to the UNI EN ISO 9001:2008 / UNI EN 13485:2012 standards and are certified with the CE Mark (Class I) and CE 0476 mark (Class IIA and class IIB) in compliance with European Medical Device Directive No. 93/42 and European Directive No. 2007/47.

All contents are updated at the time of printing. Please check in the headquarters whether any updates are available.

The contents are up to date at the time of publication.
Check with the company for any subsequent updates.