



GAV[®] 2.0

GAV[®] 2.0 LP

EN Instructions for use |

 www.miethke.com

US This Instructions for Use is NOT intended for United States users. Please discard.

The Instructions for Use for United States users can be obtained by visiting our website at www.aesculapusa.com. If you wish to obtain a paper copy of the Instructions for Use, you may request one by contacting your local Aesculap representative or Aesculap's customer service at 1-800-282-9000. A paper copy will be provided to you upon request at no additional cost.

CONTENTS

1	PREFACE AND IMPORTANT INFORMATION	4
2	INFORMATION ON HANDLING THESE INSTRUCTIONS FOR USE	4
2.1	EXPLANATION OF THE WARNINGS	4
2.2	DISPLAY CONVENTIONS	4
2.3	OTHER ACCOMPANYING DOCUMENTS AND ADDITIONAL INFORMATION	4
2.4	FEEDBACK ON THE INSTRUCTIONS FOR USE	5
2.5	COPYRIGHT, DISCLAIMER, WARRANTY AND OTHER INFORMATION	5
3	DESCRIPTION <i>GAV 2.0</i>	5
3.1	MEDICAL PURPOSE	5
3.2	CLINICAL BENEFITS	5
3.3	INDICATIONS	5
3.4	CONTRAINDICATIONS	5
3.5	INTENDED PATIENT GROUPS	5
3.6	INTENDED USERS	5
3.7	INTENDED USE ENVIRONMENT	5
3.8	TECHNICAL DESCRIPTION	6
3.9	OPERATING PRINCIPLE OF THE VALVE	6
3.10	SELECTION OF THE APPROPRIATE PRESSURE SETTING	7
3.11	PRESSURE-FLOW CHARACTERISTICS	8
3.12	PRESSURE LEVEL IDENTIFICATION IN X-RAY IMAGES	8
3.13	SYSTEM COMPONENTS	8
3.14	FUNCTIONAL SAFETY AND COMPATIBILITY WITH DIAGNOSTIC PROCEDURES	9
3.15	SUMMARY OF SAFETY AND CLINICAL PERFORMANCE	9
4	PROPERTIES <i>GAV 2.0</i>	9
4.1	PRODUCT DESCRIPTION	9
4.2	IMPORTANT SAFETY INFORMATION	10
4.3	PATIENT EDUCATION	11
4.4	TRANSPORT AND STORAGE	11
4.5	USE OF THE PRODUCT	11
4.6	EXPLANATION AND DISPOSAL	13
4.7	TECHNICAL INFORMATION	13
4.8	SYMBOLS USED FOR LABELLING	15
5	MEDICAL DEVICE CONSULTANTS	15

1 PREFACE AND IMPORTANT INFORMATION

Preface

Thank you for purchasing the medical device GAV 2.0. Please contact us if you have any questions about the contents of these instructions for use or the use of the product.

Your team at Christoph Miethke GmbH & Co. KG

Relevance of the instructions for use

WARNING

Improper handling and non-intended use of this product can cause risks and damages. Therefore, please read and closely follow these instructions for use. Always keep them to hand. Follow the safety instructions to avoid personal injury or material damage.

Scope

GAV 2.0 includes the following components:

- ▶ GAV 2.0
- ▶ GAV 2.0 LP, straight
- ▶ GAV 2.0 LP, U-formed

Additional options:

- ▶ *Reservoirs*
(including paediatric versions)
- ▶ *Prechambers*
(including paediatric versions)
- ▶ *Burrhole Deflector*
(including paediatric version)
- ▶ *Ventricular Catheter* with stylet
- ▶ *Peritoneal Catheter*

Basic UDI-DI

4041906653-MSHUNTS-0002CM

2 INFORMATION ON HANDLING THESE INSTRUCTIONS FOR USE

2.1 EXPLANATION OF THE WARNINGS

DANGER

Indicates an imminently hazardous situation which, if not avoided, will result in death or serious injury.

WARNING

Indicates a potentially hazardous situation which, if not avoided, could result in death or serious injury.

CAUTION

Indicates a potentially hazardous situation which, if not avoided, could result in minor or moderate injury.

NOTICE

Indicates information considered important, but not hazard-related (e.g. messages relating to property damage).

The symbols for danger, warning and caution are yellow warning triangles with a black edge and a black exclamation mark.

2.2 DISPLAY CONVENTIONS

Display	Description
<i>Italics</i>	Indicates <i>product names</i>

2.3 OTHER ACCOMPANYING DOCUMENTS AND ADDITIONAL INFORMATION

These instructions for use as well as translations into additional languages can be found on our website:

<https://www.miethke.com/downloads/>

The delivery includes a Patient Implant Card (IC) with IC label containing product information. The respective healthcare facility must record the information about the patient, the implant as well as the doctor in charge on the IC, and the IC label must be attached. The Patient Implant Card is thus intended to make all of the important information available to the patient in a compact form. This website also contains information about the symbols used on the Patient Implant Card together with a description on how the Patient Implant Card is to be completed by the healthcare institution.

Patient labels containing information about the product are enclosed with the delivery. The patient labels provide the treating physician with all the product information in a compact form for the patient record. For individually purchased shunt components, the patient label must be added to the existing Implant Card.

Helpful information for patients, particularly concerning the symbols on the Implant Card and the labels, is available on this website:

<https://www.miethke.com/ic/>

If you still need additional information despite carefully reading the instructions for use and the additional information, please contact us or your authorised distributor.

2.4 FEEDBACK ON THE INSTRUCTIONS FOR USE

Your opinion is important to us. Please let us know if you have any requests and criticisms about these instructions for use. We will analyse your feedback and take it into account for the next version of the instructions for use where appropriate.

2.5 COPYRIGHT, DISCLAIMER, WARRANTY AND OTHER INFORMATION

Christoph Miethke GmbH & Co. KG guarantees a faultless product that is free of material and manufacturing defects upon delivery.

No liability, guarantee or warranty for safety and functionality can be assumed if the product is modified in any way other than described in this document, if it is combined with products by another manufacturer or if it is used in any way other than for the intended purpose and the intended use.

Christoph Miethke GmbH & Co. KG points out that the reference to its trademark rights applies solely to jurisdictions in which it has trademark rights.

3 DESCRIPTION GAV 2.0

3.1 MEDICAL PURPOSE

The product GAV 2.0 is intended for shunting of cerebrospinal fluid (CSF).

3.2 CLINICAL BENEFITS

The clinical benefit of the MIETHKE shunt component GAV 2.0 as part of a shunt system is improvement of symptoms in the hydrocephalus therapy.

3.3 INDICATIONS

The following indications apply to GAV 2.0:

- ▶ Treatment of hydrocephalus

3.4 CONTRAINDICATIONS

The following contraindications apply to GAV 2.0:

- ▶ Infections in the implantation area
- ▶ Pathological concentrations levels (e.g. of blood components and/or protein) within the cerebrospinal fluid
- ▶ Intolerance to materials of the shunt system

3.5 INTENDED PATIENT GROUPS

- ▶ Patients who are treated with a CSF shunt system on account of their clinical picture

3.6 INTENDED USERS

In order to avoid risks due to false diagnoses, incorrect treatments and delays, the product must only be used by users with the following qualifications:

- ▶ Medical professionals, e. g. neurosurgeons
- ▶ Knowledge of mode of operation and intended use of the product
- ▶ Successful participation in product training

3.7 INTENDED USE ENVIRONMENT

Professional Healthcare Facilities

- ▶ Implantation under sterile operating theatre conditions

3.8 TECHNICAL DESCRIPTION

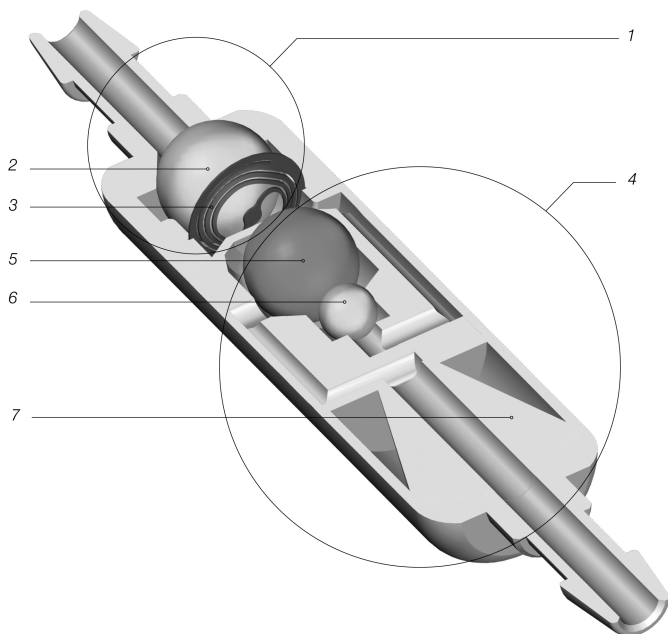

Fig. 1: GAV 2.0 cross section

1. Differential pressure unit

- 2. Sapphire ball
- 3. Micro-coil spring

The GAV 2.0 is a valve made of titanium. It consists of a differential pressure unit (1) and a gravitational unit (4). This ensures physiological intraventricular pressure (IVP) in any body position.

In the proximal part of the GAV 2.0, a micro-coil spring (3) ensures the opening pressure for the differential pressure unit. The gravitational unit in the distal part of the valve consists of a tantalum ball (5), which determines the opening pressure of this unit, and a sapphire ball (6), which ensures its precise closure. Coding (7) facilitates identification of pressure levels in an X-ray image.

4. Gravitational unit

- 5. Tantalum ball
- 6. Sapphire ball
- 7. X-ray coding

For lumboperitoneal shunting there is the GAV 2.0 LP, *straight* and the GAV 2.0 LP, *U-formed*. These LP valves have a smaller diameter connector on the inlet side to which a *Lumbar Catheter* can be connected.

3.9 OPERATING PRINCIPLE OF THE VALVE

The GAV 2.0 is a posture-dependent valve.

Horizontal body position

In the horizontal position, the gravitational unit is always open and does not present any resistance.

The opening pressure of the GAV 2.0 in this body position is thus determined by the adjustable differential pressure unit. The basic operating principle of the differential pressure unit is shown in Fig. 2 a) and b).

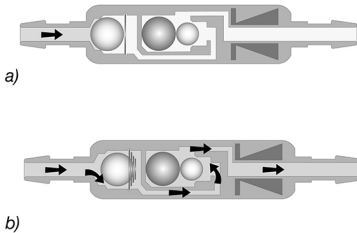

Fig. 2: GAV 2.0 in the horizontal body position
a) closed b) open

In Fig. 2a), the differential pressure unit is closed; hence, shunting is not possible. If the patient's intraventricular pressure (IVP) exceeds the spring force of the micro-coil spring, the sealing ball moves out of the cone, leaving a gap for CSF shunting (Fig. 2 b)

Vertical body position

As the patient sits or stands up, the Gravitational Unit is activated and the opening pressure of the GAV 2.0 is significantly increased (Fig. 3 a). In addition to the opening pressure of the differential pressure unit, the weight of the tantalum ball (opening pressure of the Gravitational Unit) has to be exceeded. Shunting is only possible again when the sum of intraventricular pressure (IVP) and hydrostatic suction is greater than the opening pressure of both units (Fig. 3 b).

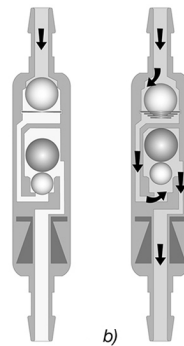

Fig. 3: GAV 2.0 in the vertical body position
a) closed b) open



CAUTION

During physical activity associated with shock (e.g. jogging), the opening pressure of the GAV 2.0 may decrease temporarily according to laboratory results. Fundamentally, though, functionality remains the same. At the end of physical activity, the opening pressure returns to its original level and remains stable.

3.10 SELECTION OF THE APPROPRIATE PRESSURE SETTING

Recommended pressure settings for the GAV 2.0 are available at:

<https://www.miethke.com/downloads/>

This is a non-binding recommendation for the treating physician. The physician decides on each case independently, individually and autonomously in accordance with his/her diagnosis.

Horizontal body position

The opening pressure in the horizontal body position is determined by the pressure level of the differential pressure unit.

Depending on the patient's clinical picture, indication and age, the opening pressure for this position can be selected between pressure levels from 5 to 10 cmH₂O.

Vertical body position

The opening pressure of the GAV 2.0 for the vertical body position is calculated from the sum of the pressure levels of the differential pressure unit and the Gravitational Unit.

Patient height, activity level and potentially increased abdominal pressure (obesity) should be taken into account in selecting the opening pressure level for the gravitational unit.

3.11 PRESSURE-FLOW CHARACTERISTICS

A flow rate of 5 to 50 ml/h causes the following pressure-flow characteristics. The pressure level at the reference flow rate of 20 ml/h is highlighted in bold. The reference flow rate is highlighted by a dotted line (---). Note that testing the product may provide different results depending on the test setup.

The combination with catheters (inner diameter > 1 mm) does not fundamentally affect the pressure-flow characteristics.

Horizontal body position

The following diagrams show the pressure-flow characteristics for the available pressure levels of the GAV 2.0 in the horizontal body position; pressure (cmH₂O), flow rate (ml/h):

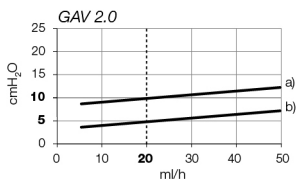

Fig. 4: Horizontal pressure-flow characteristics
 a) GAV 2.0 10/25, 10/30; tolerance: +3/-4 cmH₂O
 b) GAV 2.0 5/20, 5/25, 5/30, 5/35; tolerance: ±3 cmH₂O

Vertical body position

The following diagrams show the pressure-flow characteristics for the available pressure levels of the GAV 2.0 in the vertical body position; pressure (cmH₂O), flow rate (ml/h):

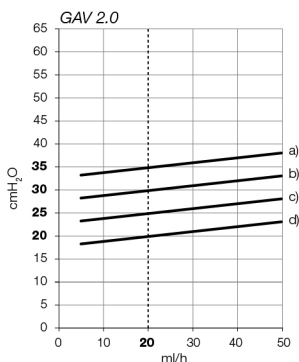

Fig. 5: Vertical pressure-flow characteristics
 a) GAV 2.0 5/35; tolerance: +3/-8 cmH₂O
 b) GAV 2.0 5/30, 10/30; tolerance: +3/-8 cmH₂O
 c) GAV 2.0 5/25, 10/25; tolerance: +3/-5 cmH₂O
 d) GAV 2.0 5/20; tolerance: +3/-5 cmH₂O

3.12 PRESSURE LEVEL IDENTIFICATION IN X-RAY IMAGES

The pressure levels of the GAV 2.0 can be identified post-surgically by the coding in the X-ray image:

Pressure level		Coding
horizontal	vertical	
5 cmH ₂ O	20 cmH ₂ O	
5 cmH ₂ O	25 cmH ₂ O	
5 cmH ₂ O	30 cmH ₂ O	
5 cmH ₂ O	35 cmH ₂ O	
10 cmH ₂ O	25 cmH ₂ O	
10 cmH ₂ O	30 cmH ₂ O	

3.13 SYSTEM COMPONENTS

Combination with shunt components

The GAV 2.0 can be safely combined with our range of implantable shunt components. We recommend using the Christoph Miethke

GmbH & Co. KG products in combination with GAV 2.0.

Reservoirs

The use of shunt systems with a reservoir makes it possible to puncture the reservoir and check the shunt function.

Any puncture of the reservoir should be performed perpendicular to the reservoir surface with a sharp cannula of max. Ø 0.9 mm. The silicone membrane can be punctured 30 times without any restrictions. A stable titanium base prevents the base from being pierced.

An integrated check valve in the *SPRUNG RESERVOIR* and the *CONTROL RESERVOIR* pumps the cerebrospinal fluid towards the valve, thus making it possible to check the distal part of the shunting system (reservoir difficult to squeeze out) as well as the *Ventricular Catheter* (reservoir fills very slowly after squeezing out). The volume per pump cycle is approx. 0.2 ml for the normal reservoirs and approx. 0.1 ml for the paediatric reservoirs with check valve.

During pumping, access to the *Ventricular Catheter* is closed. The use of a reservoir does not change the opening pressure of the shunt system.



CAUTION

Frequent pumping of the Reservoir can result in excessive shunting and thus lead to pressure conditions outside the normal physiological range. The patient should be properly informed about this risk.

Burrhole Deflector

Because of the tight fit on the *Ventricular Catheter*, the *Burrhole Deflector* makes it possible to choose the length of catheter penetrating into the skull prior to implantation. The *Ventricular Catheter* is deflected at a right angle in the burr hole (see chapter 4.5.5).

Tube systems

The GAV 2.0 can be ordered as an individual valve unit or as a shunt system with integrated catheters (internal diameter 1.2 mm, external diameter 2.5 mm). These catheters are designed for MIETHKE valves or MIETHKE shunt components with a connector outer diameter of 1.9 mm.

For lumboperitoneal shunting, there are *Lumbar Catheters* with an inner diameter of 0.8 mm

and an outer diameter of 1.6 mm. The *Lumbar Catheters* are designed for MIETHKE valves or MIETHKE shunt components suitable for lumboperitoneal shunting (outer diameter of the connector 1.4 mm).

The catheters are made from silicone and contain barium sulphate. This ensures that the X-ray image is clearly visible.

For a new connection of catheters and connectors, the catheters must be carefully secured with a ligature to the valve's connectors or shunt components.

3.14 FUNCTIONAL SAFETY AND COMPATIBILITY WITH DIAGNOSTIC PROCEDURES

- ▶ GAV 2.0 together with the entire shunt system can safely withstand pressure of up to 100 cmH₂O occurring during and after surgery.
- ▶ Nuclear magnetic resonance (MRI) examinations up to a field strength of 3 Tesla or computed tomography (CT) examinations can be performed without danger or impairment to the valve function. The GAV 2.0 is MR Conditional. The *Catheters* are MR Safe. *Reservoirs*, *Prechambers*, *Burrhole Deflectors* and *Titanium Connectors* are MR Conditional. The stylet is MR Unsafe.

The conditions for MRI security of the products are found on our website: <https://miethke.com/downloads/>

3.15 SUMMARY OF SAFETY AND CLINICAL PERFORMANCE

The summary of safety and clinical performance (SSCP) can be downloaded from the following address:

<https://www.miethke.com/downloads/>

4 PROPERTIES GAV 2.0

4.1 PRODUCT DESCRIPTION

4.1.1 GAV 2.0 VARIANTS

The GAV 2.0 is available in a range of different variants. They differ in the pre-set pressure level depending on body position.

GAV 2.0	Horizontal	Vertical
5/20	5 cmH ₂ O	20 cmH ₂ O

GAV 2.0	Horizontal	Vertical
5/25	5 cmH ₂ O	25 cmH ₂ O
5/30	5 cmH ₂ O	30 cmH ₂ O
5/35	5 cmH ₂ O	35 cmH ₂ O
10/25	10 cmH ₂ O	25 cmH ₂ O
10/30	10 cmH ₂ O	30 cmH ₂ O

These variants are also available as shunt systems and can come with the following components: *Ventricular Catheters, Peritoneal Catheters, Prechambers, Reservoirs.*

4.1.2 SCOPE OF DELIVERY

Box content	Number
GAV 2.0 Shunt system sterile packaging	1
Instructions for use for GAV 2.0	1
Patient Implant Card (IC)	1
IC label	6
Patient label	6
Insert regarding the Patient Implant Card	1
Pressure level recommendation	1

4.1.3 STERILITY



WARNING

The products must not be used if the packaging or the product is damaged or after the expiry date.

The products are sterilised with steam under strictly controlled conditions. The respective expiry date is printed on the packaging.

4.1.4 REPEATED USE AND RESTERILISATION



WARNING

The product must not be resterilised or reprocessed in any other way as the safe functioning and sterility of the product cannot be guaranteed.

Products that have already been implanted in a patient must not be reused either on the same or a different patient in order to minimise the risk of infection.

4.1.5 PRODUCT LIFETIME

The technical lifetime of the medical device GAV 2.0 is 15 years. Patient-specific circumstances or known side effects such as biological deposits or infection can shorten the lifetime and make revision necessary. In a favorable case, the real lifetime can also exceed the expected time span.

4.1.6 SINGLE-USE PRODUCT

This product is intended for single use. Reprocessing may lead to significant changes to the properties of the GAV 2.0. No guarantee can be assumed for the functional safety of resterilised products.

4.1.7 PRODUCT CONFORMITY

The product meets current regulatory requirements.

The requirements stipulate the comprehensive documentation of the whereabouts of medical devices used in humans. The individual identification number of the medical device should therefore be recorded in the patient's medical records to ensure complete traceability.

4.2 IMPORTANT SAFETY INFORMATION

4.2.1 SAFETY INSTRUCTIONS

Important! Read all safety instructions carefully before using the product. Follow the safety instructions in order to avoid injuries and life-threatening situations.



WARNING

- ▶ **The products must not be used if the packaging or the product is damaged or after the expiry date.**
- ▶ **Due to the risk of injury resulting from incorrect use of the product, the instructions for use must be carefully read and understood before the product is used for the first time.**
- ▶ **Prior to use, it is essential to check the product for completeness and integrity.**

4.2.2 COMPLICATIONS, SIDE EFFECTS, PRECAUTIONS AND RESIDUAL RISKS

The following complications can occur in conjunction with the GAV 2.0:

- ▶ Headaches, dizzy spells, mental confusion, vomiting in cases of possible leakage from the shunt system and shunt dysfunction
- ▶ Redness/irritation of the skin and tightness around the implantation site as an indication of a possible infection at the implant
- ▶ Occlusions caused by protein and/or blood components in the cerebrospinal fluid
- ▶ Overdrainage/underdrainage
- ▶ Noise development
- ▶ Allergic reaction / intolerance to product materials

Violent external shocks (accident, fall etc.) may put the integrity of the shunt system at risk.

As a precaution, a physician must be consulted immediately if the patient suffers from skin rashes and tightness, severe headaches, dizzy spells or similar.

The following residual risks exist when using the GAV 2.0:

- ▶ Persistent headache
- ▶ Severe infection (e.g. sepsis, meningitis) / allergic shock
- ▶ Acute and chronic hygroma/subdural haematoma
- ▶ Cerebrospinal fluid accumulations
- ▶ Tissue damage/puncture
- ▶ Skin irritation
- ▶ Local shunt irritation /allergic reaction

4.2.3 REPORTING OBLIGATION

All serious incidents (damage, injuries, infections, etc.) occurring in relation to the product must be reported to the manufacturer and the responsible state authority.

4.3 PATIENT EDUCATION

The attending physician is responsible for informing the patient and/or his/her proxy in advance. The patient is to be informed about warnings, precautions, contraindications, precautionary measures to be taken as well as restrictions on use in relation to the product. (Ch. 4.1.5, 4.2, 4.5, 4.7).

4.4 TRANSPORT AND STORAGE

The medical devices must always be transported and stored in a clean and dry place.

4.4.1 TRANSPORT

Transport conditions

Temperature range for transport	-30 °C ... +40 °C
--	-------------------

4.4.2 STORAGE

Storage conditions

Temperature range for storage	room temperature
--------------------------------------	------------------

4.5 USE OF THE PRODUCT

4.5.1 INTRODUCTION

The GAV 2.0 is a posture-dependent valve with a pre-set differential pressure unit and a pre-set gravitational unit.

The GAV 2.0 is used for shunting cerebrospinal fluid (CSF) into the peritoneum in the treatment of hydrocephalus. Valves and Reservoirs are placed in suitable positions along the course of the shunt.

4.5.2 SAFETY NOTICES AND WARNINGS



WARNING

- ▶ **The correct flow direction must be strictly observed as per the arrows. Incorrect implantation will result in flow prevention and underdrainage.**
- ▶ **The gravitational unit of the GAV 2.0 is posture-dependent. For that reason, care must be taken to implant the gravitational unit parallel to the body axis.**
- ▶ **Silicone is extremely electrostatic. Care must be taken to avoid the catheters coming into contact with dry cloths, talcum powder or rough surfaces. Clinging particles could lead to tissue reactions.**
- ▶ **When using sharp instruments, care should be taken to avoid cuts and scratches in the silicone elastomer.**
- ▶ **It must be ensured that the ligature is not tightened excessively. Damage may result in a loss of integrity of the shunt and thus necessitate a revision.**

WARNING

- ▶ The catheters should only be blocked with an atraumatic clamp and not directly behind the shunt component (e.g. valve, reservoir or connector) as they might be damaged otherwise.

CAUTION

- ▶ Frequent pumping of the Reservoir can result in excessive shunting and thus lead to pressure conditions outside the normal physiological range. The patient should be properly informed about this risk.

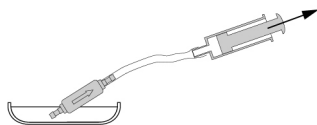

Fig. 6: Patency test

WARNING

- ▶ Contaminants in the solution used for testing can impair the product's performance.
- ▶ Pressurisation with a single-use syringe should be avoided both at the proximal and the distal end (Fig. 7).

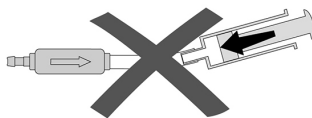

Fig. 7: Avoidance of pressurisation

4.5.3 REQUIRED MATERIALS

The GAV 2.0 is designed so that it can be safely used with the shunt components described in chapter 3.13.

Catheters with an inner diameter of 1.2 mm and an outer diameter of 2.5 mm should be used for connection. For inlets in LP versions, *Lumbar Catheters* with an inner diameter of 0.8 mm and an outer diameter of 1.6 mm should be used for connection. In any case, catheters have to be carefully secured with a ligature to the connectors of the shunt components. Any kinks in the catheter must be avoided.

4.5.4 PREPARING FOR IMPLANTATION

Checking the sterile packaging

Immediately before using the product, the sterile packaging must be visually inspected in order to check the integrity of the sterile barrier system. The products should only be removed from the packaging immediately prior to use.

Preoperative valve test

The GAV 2.0 should be vented before implantation and checked for permeability. The most careful way of filling the valve is by aspiration through a sterile single-use syringe attached to the distal end of the catheter. The distal end of the valve is connected and immersed in a sterile physiological salt solution. The valve is patent if saline solution can be extracted (Fig. 6).

4.5.5 PERFORMING THE IMPLANTATION

Positioning of the Ventricular Catheter

Several surgical techniques are available for the positioning of the *Ventricular Catheter*. The required skin incision should be made in form of a lobule pedicled towards the shunting catheter or by a straight skin incision. If a *Burrhole Reservoir* - or a *SPRUNG RESERVOIR* - is used, the skin incision should not be located right above the reservoir. To avoid CSF leakage, care should be taken that the dura opening is kept as small as possible after applying the burr hole. GAV 2.0 is available in a range of different configurations: If using a *Burrhole Reservoir* - or a *SPRUNG RESERVOIR* -, the *Ventricular Catheter* is implanted first. Once the mandrin has been removed, the patency of the *Ventricular Catheter* can be tested by checking if cerebrospinal fluid is dripping out. The catheter is shortened and the *Burrhole Reservoir* - or the *SPRUNG RESERVOIR* - connected and the connection secured with a ligature.

When using a shunt system with a *CONTROL RESERVOIR*, a *Burrhole Deflector* is included. The *Burrhole Deflector* is used to adjust the length of the catheter to be implanted and to position it inside the ventricle. The *Ventricular Catheter* is deflected by 90° and the *CONTROL RESERVOIR* put into place. The position of the

Ventricular Catheter should be inspected after the procedure by imaging (such as CT or MRI).

Valve positioning

For ventriculoperitoneal shunting, a location behind the ear is suitable as an implantation position, whereby the implantation height has no influence on the valve function.

A large arch-shaped or a small straight skin cut with a pocket for the valve should be made. The catheter is pushed forward from the burr hole to the selected valve implantation location, shortened if necessary, and secured to the GAV 2.0 by ligature. The valve should not be located directly under the skin incision. The valve unit has an arrow in the flow direction (arrow towards distal or downwards).



WARNING

- ▶ **The correct flow direction must be strictly observed as per the arrows. Incorrect implantation will result in flow prevention and underdrainage.**
- ▶ **The gravitational unit of the GAV 2.0 is posture-dependent. For that reason, care must be taken to implant the gravitational unit parallel to the body axis.**

Therefore, when using a shunt system in which the valve has been pre-fitted with a *Burrhole Reservoir* or a *SPRUNG RESERVOIR*, only the occipital access should be used.

Positioning of the *Peritoneal Catheter*

The access site for the *Peritoneal Catheter* is left to the surgeon's discretion. For example, it can be used in a paraumbilical application or applied at the level of the epigastrium. Likewise, various surgical techniques are available for placing the *Peritoneal Catheter*.

The recommendation is to pull the *Peritoneal Catheter* from the valve to the intended position using a subcutaneous *Tunneller*, if necessary with the aid of an auxiliary incision. The *Peritoneal Catheter*, usually securely attached to the valve, has an open distal end and no wall slits.

Following the exposure of the peritoneum or with the aid of a trocar, the *Peritoneal Catheter* (shortened if necessary) is pushed forward into the open space of the abdominal cavity.

4.5.6 POSTOPERATIVE TEST

Postoperative valve test

The GAV 2.0 has been constructed as a reliably functioning unit without pump or test function. The valve test can be performed by flushing, pressure measurement or pumping via a *Reservoir* or a *Prechamber*.

4.6 EXPLANTATION AND DISPOSAL

4.6.1 EXPLANTATION

The explantation of the GAV 2.0 should be performed according to the state of the art and in compliance with medical practice.

4.6.2 DISPOSAL

GAV 2.0 and shunt components

Products and product parts not used in the implantation or surgically removed must be disposed of correctly as potentially infectious material in accordance with medical practice as well as respective regional laws and regulations.

4.7 TECHNICAL INFORMATION

4.7.1 MATERIALS THAT COME INTO CONTACT WITH BODILY TISSUE/ FLUIDS

Quantitative material properties

All implantable parts of a shunt system with direct contact to body tissues or fluids are biocompatible and are composed as follows:

- ▶ Titanium alloy TiAl₆V₄ (ASTM F136)
- ▶ Titanium grade 1 (ASTM F67)
- ▶ Tantalum (ASTM F560)
- ▶ White sapphire Al₂O₃ (ISO 6474-1)
- ▶ Silicone elastomer (long-term implantable)
- ▶ Polyester ligature

4.7.2 TECHNICAL DATA

Manufacturer	Christoph Miethke GmbH & Co. KG
Product designation	GAV 2.0

Medical Purpose	Shunting of cerebrospinal fluid (CSF)
Sterilisability	Cannot be resterilised
Storage	Store in a clean and dry place room temperature

For single use only

Sketch with outer dimensions:

GAV 2.0 (VP shunting)

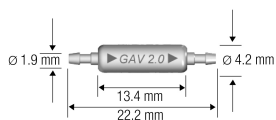



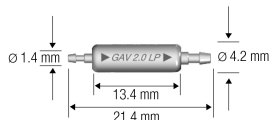



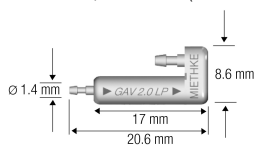











GAV 2.0 LP, straight (LP shunting)





GAV 2.0 LP, U-formed (LP shunting)



4.8 SYMBOLS USED FOR LABELLING

Symbol	Explanation
	EU conformity marking, xxx indicates the identifier of the responsible notified body
	Medical Device
	Manufacturer
	Date of manufacture
	Use by
	Batch name
	Catalogue number
	Serial number
	Unique Device Identification
UDI-DI	UDI-DI number
	Vapour or dry heat sterilised
	Do not resterilise
	Do not reuse
	Double sterile barrier system
	Do not use if the packaging is damaged; and follow the instructions for use
	Store in a dry place
	Temperature limits
	Consult instructions for use / electronic instructions for use
	Caution

Symbol	Explanation
	Pyrogen-free
	Free of natural rubber latex, latex-free
	Indicates that in the USA, the product may only be issued to physicians.
	MR Conditional
	Patient identification
	During implantation
	Outpatient clinic or physician
	Website with patient information
	Model number / European Medical Device Nomenclature Code

5 MEDICAL DEVICE CONSULTANTS

In compliance with regulatory requirements, Christoph Miethke GmbH & Co. KG has nominated medical device consultants as contacts for all product-related questions.

You can contact our medical device consultants at:

Tel. +49 331 62083-0

info@miethke.com



 Technical alterations reserved

Manufacturer:



Christoph Miethke GmbH & Co. KG | Ulanenweg 2 | 14469 Potsdam | Germany

Phone +49 331 620 83-0 | Fax +49 331 620 83-40 | www.miethke.com

注册人: Christoph Miethke GmbH & Co. KG 克里斯托福弥提柯股份有限公司

住所: Ulanenweg 2, 14469 Potsdam, Germany

联系方式: www.miethke.com, info@miethke.com

Distributor:



Aesculap AG | Am Aesculap-Platz | 78532 Tuttlingen | Germany

Phone +49 7461 95-0 | Fax +49 7461 95-2600 | www.bbraun.com

AESCULAP® - a B. Braun brand